

Perception and Action in Teleoperated Needle Insertion

Ilana Nisky, Assaf Pressman, Carla M. Pugh, Ferdinando A. Mussa-Ivaldi, *Member, IEEE* and Amir Karniel, *Senior Member, IEEE*

Abstract— We studied the effect of delay on perception and action in contact with a force field that emulates elastic soft tissue with a rigid nonlinear boundary. Such field is similar to forces exerted on a needle during teleoperated needle insertion. We found that delay causes motor underestimation of the stiffness of this nonlinear soft tissue, without perceptual change. These experimental results are supported by simulation of a simplified mechanical model of the arm and neural controller, and a model for perception of stiffness, which is based on regression in the force-position space. In addition, we show that changing the gain of the teleoperation channel cancels the motor effect of delay without adding perceptual distortion. We conclude that it is possible to achieve perceptual and motor transparency in virtual one-dimensional remote needle insertion task.

Index Terms— Medical Simulation, Perception and Psychophysics, Telemanipulation, Transparency.

1 INTRODUCTION

TELESURGERY can substantially improve patient care and surgical training by providing global access to surgical specialists [1, 2]. In telesurgery, the surgeon determines the motion of a remote slave robot by moving a master robot and senses the forces reflected from the slave to the master (Fig. 1a). Telesurgery requires transmission of information from a distance, and therefore, delay is unavoidable.

In the last decade, we have extensively studied the influence of delay between position and force on the perception of mechanical stiffness of spring-like force fields [3, 4, 5], and on action during contact with such force fields [6]. We found that subjects tend to overestimate stiffness when force lags position [3], and that shifting the boundary also modifies stiffness perception [6]. The effect of delay on perception depends on the way in which the surface is probed by repeated contacts [4]: when the hand of subjects remained in continuous contact with the elastic force field they tended to underestimate the delayed stiffness. Moreover, we found a proximal-distal gradient in the amount of underestimation of delayed stiffness in the transition between probing with shoulder, elbow, and wrist joints [5]. Interestingly, cognitive and motor representations of the world around us in general [7, 8, 9], and of mechanical properties of objects in particular, are not always mutually consistent. We found inconsistencies between declarative and motor-related perception of linear stiffness [6]. However, these inconsistencies were

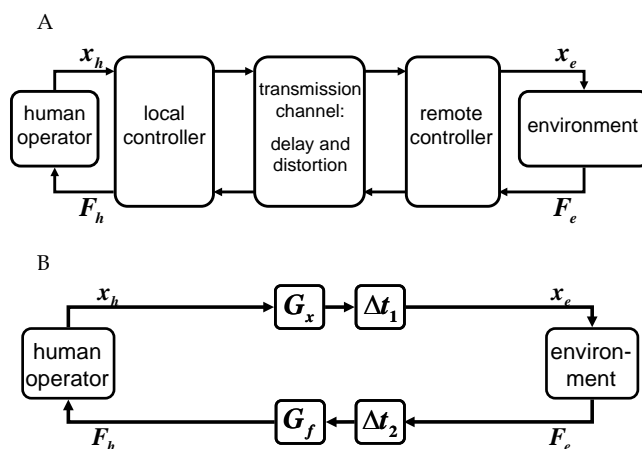

Fig. 1. Teleoperation system: (A) In the general case the human operator (a surgeon) acts through a local controller, a channel, and a remote controller on the remote environment with delayed and distorted feedback. (B) In a simplified case, the human operator interacts with a haptic environment that simulates an architecture that includes only delay (Δt), transmission gain (G), and nonlinear tissue-like environment. x_h and F_h are the position of the human operator's hand and the forces applied on it by the local robotic device (haptic interface) respectively, and x_e and F_e are the simulated position of the remote device and the force exerted by the environment on the device.

found in separate experiments, with different subjects.

In the current study, we developed a new protocol to probe the effect of delay on perception and action in the same experiment. This is important in order to verify that the difference between the effects is not because some uncontrolled difference between the experiments, and that both effects take place at the same time. In section 2, we elaborate on the importance of probing these two effects in the same experiment. We employed this new protocol on simulated telesurgery, and focused on a simple teleoperation architecture, in which the transmission channel is corrupted by pure delay and changes in gain (Fig. 1b). We chose this specific channel in order to high-

- I. Nisky, A. Pressman, and A. Karniel are with the department of biomedical engineering, Ben-Gurion University of the Negev, Beer-Sheva, Israel 84105. E-mail: {nisky, pressman, akarniel}@bgu.ac.il.
- C.M. Pugh is with the Feinberg School of Medicine, Northwestern University, 201 E Huron St, Chicago, IL, 60611. E-mail: cpugh@nmh.org.
- F.A. Mussa-Ivaldi is with the Sensory Motor Performance Pro-gram, Rehabilitation Institute of Chicago, 345E. Superior Street, Chicago IL 60611. E-mail: sandro@northwestern.edu.

light the effects of delay without additional control considerations [10, 11]. We used this protocol to test the effect of the addition of a nonlinear boundary region to a linear spring-like force field, which together simulate needle insertion into soft tissue [12, 13], and the effect of delay on perception and action in contact with such a field. In addition, we showed that it is possible to compensate the effect of delay on motor performance in the needle insertion task without adding perceptual distortion; namely, we achieved perceptual and motor transparency [14] in this simulation of teleoperated needle insertion. Preliminary results of this study were presented at a conference [15]. In the current paper, we present a full study with additional subjects, thereby reinforcing the results of the preliminary data, together with a new simulation study that accounts for our experimental results.

The rest of this paper is organized as follows: We briefly review our idea of perceptuo-motor transparency for telesurgery in section 2, and describe the simulated needle insertion task in section 3. Sections 4 and 5 describe our experimental and simulation studies in sections 4 and 5, respectively. Section 6 concludes the paper with a brief discussion.

2 PERCEPTUAL AND MOTOR TRANSPARENCY

Transparency is a measure of teleoperation system fidelity. The ideal, identity channel, is by definition completely transparent. In such a channel, the force and/or position information is transmitted between both sides of teleoperation system accurately, without any distortion or delay. Various definitions and conditions for transparency have been presented, e.g. network functions, such as impedance or admittance [11, 16, 17], or correspondence of position and force signals [18, 19]. The common feature between most of the studies of transparency is that they define the transparency over the teleoperation channel alone, and do not include the human operator as part of the system. In such a framework, ideal transparency conditions are unattainable [20], particularly in the presence of transmission delays [10, 17], and there is a stability-transparency tradeoff [11]. The human operator was taken into account in previous studies by considering force perception thresholds [21], just noticeable difference (JND) for mechanical properties and time delay [20, 22], or relative change in impedance of the environment [22]. However, none of these studies addressed the bias in perception of mechanical properties that is caused by delay, nor did they take into account the gap between perception and action in the motor system.

In the current study, we examined the effect of delay on perception and action in the same experimental setup. In the following section, we will try to emphasize why this is important, in particular for teleoperation and telesurgery. Several studies have reported inconsistency between perception and action in various tasks [7, 8, 9, 23], such as grasping [8, 23] and placing a card into a slot [7, 24]. Dissociation between perception and action was also demonstrated in reproduction of remembered distances [25]. Recently, we have found that declarative and motor-

related estimations of stiffness are inconsistent [6]. Interestingly, inconsistencies between perception and action are evident in many adaptation tasks. For example, in adaptation to force fields [26], many of the subjects report that by the end of training they no longer feel the field, and when the force field is suddenly removed, they report that they felt a force field that was actually absent.

Taking these concepts to the realm of telesurgery, we consider a remote surgical procedure that requires cutting a soft connective tissue while avoiding damage to stiffer vessels and muscle tissue. In this scenario, there are two actions: probing and cutting, and two perceptions: soft tissue and stiff tissue. The surgeon acts in a local virtual environment, but the actual procedure is performed on a remote patient via a teleoperation system. Three potential problems may arise: 1) the surgeon can misperceive soft connective tissue as stiff muscle/vessel tissue; 2) the surgeon can virtually damage the local model of the tissue when she wishes to probe the tissue; 3) the surgeon can actually damage the real remote tissue when she intends to probe it. These three problems correspond to three aspects of transparency:

1. *Perceptual transparency*: The human operator cannot distinguish between the system and an identity channel.
2. *Local motor transparency*: The movement of the operator does not change when the teleoperation system is replaced by an identity channel.
3. *Remote motor transparency*: The movement of the remote robot does not change when the teleoperation system is replaced by the identity channel.

In our previous studies [14], we suggested that it is possible to obtain perceptually transparent teleoperation and remote motor transparency without local motor transparency. In practice, local motor transparency is relatively unimportant, since the motor goal of any teleoperation task is defined in the remote environment, and the most realistic perception must be rendered in the local environment. Perceptual and remote motor transparencies are simultaneously attainable by either changing the local or the remote controllers or by training the human operator. We call the process of selecting optimal controllers and training protocols *transparentizing*. In this paper, we show that it is possible to achieve remote motor transparency in the needle insertion task by decreasing the gain of our simplified teleoperation channel below unity without sacrificing the perceptual transparency. This, of course, comes with the cost of imperfect local motor transparency, since the actual movements of subjects are hypermetric due to the reduced gain.

3 NEEDLE INSERTION TASK

3.1 Nonlinear Force Field

In our previous studies, we have explored the effect of delay on perception of linear stiffness [3, 4, 5], and on action in contact with linear spring-like force fields [6]. However, biological tissues do not have the mechanical behavior of simple linear elastic spring; rather, they show viscoelastic, inhomogeneous, nonlinear, and anisotropic

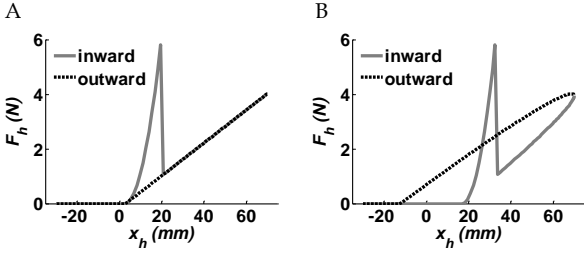

Fig. 2. A nonlinear force field approximates the force profile during needle insertion. (A) Trajectory of nonlinear tissue force field in force-position space. The operator first encounters a rigid nonlinear boundary on the way into the force field, and only after a penetration of 17mm, there is a sudden drop in the applied forces. From that point, the force field is equivalent to a linear one-sided spring. (B) Trajectory of nonlinear tissue force field with delay: force lags position, and therefore, a hysteresis-like trajectory is formed.

properties [12, 27, 28, 29, 30, 31, 32, 33, 34, 35]. Therefore, in order to develop successful telesurgery systems, it is important to extend the understanding of the effect of delay on perception and action to a more realistic environment.

There are various surgical procedures in which accurate haptic information may be beneficial, such as suturing, cutting, needle insertion, and diagnostic palpation. We chose the needle insertion task for evaluation of action due to the relative simplicity of this task: the movement is one-dimensional; the accuracy of the insertion is determined by a single point in space – the reversal, or maximal penetration point; and the contact with the tissue is a one-point contact at the tip of the needle. Although this movement is simple, it is important from the clinical perspective, since many modern clinical procedures involve percutaneous needle insertion, such as biopsies, anesthesia, neurosurgery, radiotherapy and brachytherapy [12, 36, 37].

Mechanical interaction with soft tissue during percutaneous needle insertion typically requires transition through a rigid nonlinear boundary, followed by a movement inside underlying softer viscoelastic material (Fig. 2). Such force position relation is of special interest, as it involves precise control around the boundary region. However, as a first attempt to evaluate the effect of delay on a nonlinear force field, we chose a simplified model. In this model, the reaction forces were simulated to depend only on the position and direction of movement. Therefore, the force $F_h(t)$, which was exerted on the hand of the human operator, was a nonlinear function of the hand displacement $x_h(t)$, similar to the position dependent component in [13]:

$$x_e(t) = x_h(t - \Delta t_1) \cdot G_x$$

$$F_e(t) = \begin{cases} 0 & x_e(t) < x_0 \\ k_{b1}(x_e(t) - x_0) + \\ k_{b2}(x_e(t) - x_0)^2 & x_0 < x_e(t) < x_b; \dot{x}_e(t) > 0 \\ k_i(x_e(t) - x_0) & x_e(t) > x_b \\ k_i(x_e(t) - x_0) & x_0 < x_e(t) < x_b; \dot{x}_e(t) < 0 \end{cases} \quad (1)$$

$$F_h(t) = F_e(t - \Delta t_2) \cdot G_f,$$

where G_x, G_f are position and force gains, respectively; $x_0 = 3mm$ is the position of the boundary of the field;

$x_b = 20mm$ is the position of the interface between rigid nonlinear boundary and the underlying linear tissue; $x_e(t), \dot{x}_e(t)$ and $F_e(t)$ are position, velocity, and force at the environment side; and $\Delta t_1, \Delta t_2$ are the delays. In Fig. 2 the force-position trajectories of such force field with and without delay are depicted.

3.2 Slicing Movement

In our studies of the effect of delay on action, we searched for an objective measure of the expected stiffness, based on the hand movement at catch trials, where delays were unexpectedly removed [6]. To achieve this, we asked subjects to perform an accurate forth and back “slicing” movement with the peak penetration at a predefined goal, as they probe a virtual force field. In the current study, we used the same paradigm to probe the effect of delay on action, and we combined it with forced choice questions about perception. Therefore, our indicative task for skillful needle insertion is a successful forth and back slicing movement towards a predefined goal inside the linear part of the force field. In order to succeed in this task, the participants had to penetrate the tissue, and move beyond the rigid boundary. This movement is used in the clinical setting for fine needle aspiration of palpable and non-palpable lesions [38]. As such, it is beneficial in our experimental paradigm due to the following assumptions:

1. Subjects can rapidly learn to perform a slicing movement towards a target with knowledge of results feedback only.
2. Subjects plan their slicing movements based on the expected stiffness, estimated according to the preceding movements.
3. The control of a rapid slicing movement is a feed-forward control. The effect of feedback during the movement is neglected, and sensory information is used only to estimate the stiffness and to modify the motor command of the next movement.

The slicing movement can be modeled by combining two fifth order polynomials representing two reaching movements: to and from the target, as derived by minimizing the jerk [39]. Experimental studies showed that this is a reasonable approximation for natural movements in free space [40, 41].

4 EXPERIMENTAL STUDY

4.1 Methods

Experiment 1: Motormetric and psychometric effect of delay

Twenty-one subjects participated in the experiments after signing the informed consent form as stipulated by the Soroka Helsinki Committee and by the Institutional Review Board at Northwestern University. Seven of the subjects performed the experiment at the Rehabilitation Institute of Chicago, and fourteen subjects performed the same experiment at Ben-Gurion University of the Negev. The results of the experiment performed in Chicago were reported in [15]. The same researchers (IN, AP) per-

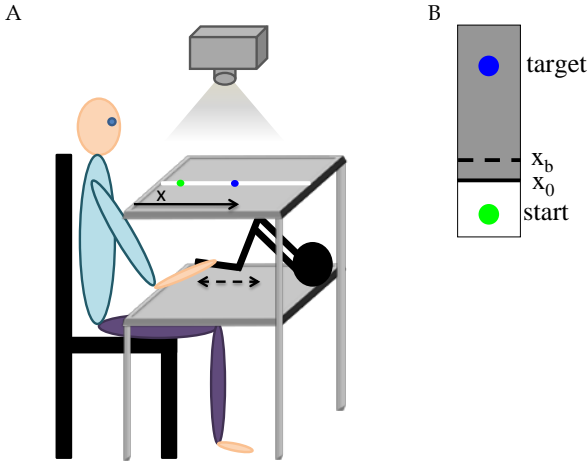

Fig. 3. Experimental setup. (A) Seated participant holds the handle of a robotic device without seeing his hand. He is presented with partial visual feedback in task irrelevant dimension (lateral movements – white line). Solid arrow shows the x direction of experiment. The participants are requested to move their hand and robotic device along the anterior-posterior (x) direction, as shown by the broken arrow. (B) Schematic representation of the experimental screen view. Only start and target are visible to the subject. x_0 is the position of the boundary of the field, and x_b is the position of the interface between rigid nonlinear boundary and the underlying linear tissue. Both boundaries are not visible to the participant.

formed the experiments in similar setups, and we found no differences in the results. We therefore analyzed the data of all 21 subjects together.

Seated subjects held the handle of a PHANTOM® Premium 1.5/6DOF haptic device, and looked at a horizontal screen placed above their hand. The screen displayed start and target positions (Fig. 3), and the haptic device exerted forces on the hand of the subject and acquired its trajectory at 1KHz. Lateral position of the hand was displayed by a line, and provided subjects with partial position information, without revealing the penetration into a haptic virtual object.

Subjects were instructed to quickly reach the target and then return to the starting point. Such a slicing movement completed a single trial. Performance feedback was provided as written text messages (“long”, “short” or “exact”) that were presented to the subject after returning back to start position. The target was located 67 mm beyond the boundary of the field, x_0 ; the start point was located 33mm away from the boundary (Fig. 3B). The experiment consisted of two phases: training and test.

The purpose of the training phase was to allow the participants to become acquainted gradually with the task, the robotic device, its dynamics and the interaction with it, and the different force fields that they encountered during the test phase. Training consisted of 100 movements, and included four stages:

1. Null training – 20 movements in free space.
2. Linear field training – 20 movements into a linear elastic force field that starts at $x=x_0$ with $k_t=k_{b1}=0.06$ N/mm and $k_{b2}=0$ (similar to the linear part of the force-position trajectory in Fig. 2A).
3. Nonlinear field training – 40 movements with 10 randomly ordered blocks of nonlinear force fields (Fig. 2A) with $k_{b1}=0.02$ N/mm, $k_{b2}=0.02$ N/mm² and

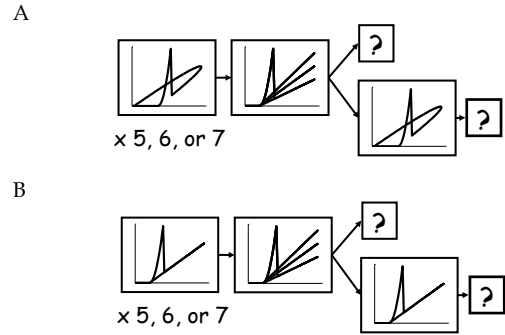

Fig. 4. The structure of a single test phase block. Each block consisted of 6-9 trials, including 5-7 training trials with either delayed (A) or non-delayed (B) nonlinear force field, followed by one of 10 possible non-delayed catch trials, followed by either a question or a repetition of the trained field trial and then a question.

k_t stiffness levels chosen from $k_t = 0.025, 0.035, 0.045, 0.055, 0.065, 0.075, 0.085, 0.095, 0.105, 0.115$ N/mm. Each block included four trials. This training allowed subjects to become acquainted with the various tissue stiffness levels that were later presented during catch trials of the experiment.

4. Delayed field training – 20 movements with nonlinear delayed force field where $k_{b1}=0.02$ N/mm, $k_{b2}=0.02$ N/mm², $k_t = 0.06$ N/mm, and $\Delta t_1 = \Delta t_2 = 25$ ms (Fig. 2B).

After completing the training phase, the subjects performed 1205 movements in the test phase. The purpose of the test phase was to extract the effect of delay on perception and action. We used a combination of two protocols from our previous studies [3, 4, 5, 6]. In general, we explored the cognitive representation of rigidity by asking subjects which of two force fields was stiffer, and evaluated the motor representation by investigating adaptation to the same force fields. We have introduced the term “motormetric” – as a contrast to “psychometric” – analysis to designate procedures that are based on observable motor actions for assessing the evolution of perceptual models [6]. We assumed that subjects who were trained to perform slicing movements to a certain point inside the force field would miss the target (overshoot/undershoot) whenever the surface properties were unexpectedly changed. Therefore, the subject performed a series of movements in either a delayed or a non-delayed nonlinear force field. Each series consisted of a 5 to 7 repetitions of identical trials with $k_{b1}=0.02$ N/mm, $k_{b2}=0.02$ N/mm², $k_t = 0.06$ N/mm, and $\Delta t_1 = \Delta t_2$ of either 25ms or 0ms, respectively. Following this series, we introduced a catch trial, in order to probe the changes in motormetric estimation [6]. In this trial, the stiffness of the linear elastic tissue after the boundary (k_t) was unexpectedly changed to one of the values specified in stage 3 of the training phase and the delay was always 0. The catch trial was either followed by a question (“Which force field was stiffer – the current or previous?”) or by another trial similar to the training block and then the question. This provided us with a psychometric evaluation of stiffness perception. Performance feedback was not provided for trials

in which the subject's response was required and for one randomly selected trial in each training block. We called such a series with catch trial and question a single block (Fig. 4). The whole test phase consisted of 20 different blocks: 10 different catch field stiffness levels and 2 different trained fields (with and without delay). The total number of trials was determined such that each of the different 20 blocks repeated exactly 8 times. The order of the presentation of the blocks and the number of repetitions within each series was randomly predetermined and similar for all participants.

The values of stiffness and the number of trials were chosen according to our previous studies [4, 5, 6], and in accordance with the penetration of needle during puncture of the liver [13]. The value of the nonlinear component of the boundary region was chosen to be higher than the respective values of living tissue. As a result, the boundary region was rigid, and the maximal forces were larger than the maximal forces of the internal tissue in case of penetration exactly to the target (see Fig. 2).

A psychometric curve quantifies the subject's performance in a discrimination task. The psychometric function relates the subject's responses to an independent variable, usually some physical measure of the stimulus [42, 43]. We used a procedure that is described in detail in [4, 5, 6] to fit psychometric functions to the probability of answering that the training block field was stiffer as a function of the difference in k_t between the catch field and the trained field [42, 43], and extract the point of subjective equality (PSE). The PSE is the difference (in units of N/mm) between the two underlying elastic tissue stiffness levels for which the subject did not perceive any difference, as evidenced by a probability of 0.5 to answer that the trained field had higher level of stiffness (see example of psychometric curve and PSE in Fig. 5A, right panel). The "motormetric curve" is a curve that relates subject's motor, and not verbal, responses to the stimulus. We used a procedure that is described in [6] to fit motormetric functions. These were fitted to the probability to overshoot at catch trial relative to the median of penetration in the last three trials in the training block as a function of the difference in k_t between the catch force field and the trained force field, and extracted the point of motor response equality (PMRE). The PMRE is the difference (in units of N/mm) between underlying elastic tissue stiffness level when the subject showed identical motor behavior, as evident by probability of 0.5 to overshoot at catch trial (see example of motormetric curve and PMRE in Fig. 5A, left panel). Positive values of these PSE or PMRE indicate underestimation of the stiffness of the trained field, and negative values indicate overestimation. Altogether, we extracted two PSE values, and two PMRE values from each experiment, for the delayed and non-delayed trained force fields. There was no actual difference between trained and catch trial in the non-delayed condition besides the difference in k_t and therefore, we do not expect to see a shift of the psychometric curve. Accordingly, the values of PSE and PMRE of the non-delayed condition are expected to be zero, and provide a control experiment for each subject. If delay has an effect on the

perceptual- or motor-related representation of the stiffness of the nonlinear elastic force field, the psychometric and motormetric curves of the delayed condition are expected to shift, and yield a nonzero value of PSE and PMRE, respectively.

We used the control psychometric and motormetric curves to build a criterion for exclusion of subjects from the study. For each subject, we calculated the proportion of correct responses in non-delayed condition. Ideally, in the baseline trials, the subject should answer (or overshoot) according to the actual difference between the stiffness levels of k_t . In this case, the correct responses are expected to occur with 100% relative frequency. In the worst case, when subjects answer (or move) regardless to what they have experienced, the correct responses are expected to occur with only 50% relative frequency. We defined failure in the psychometric or motormetric task when the frequency of correct responses in the non-delayed condition was below 65%. Six subjects failed in the psychometric component of the task, and two subjects failed in the motormetric component of the task. In previous psychometric studies, we used a 70% frequency threshold [4]. As the current psychometric task was far more difficult, since there was only one constrained probing per force field, we chose to lower the percentile for inclusion. Nevertheless, our results are statistically significant even with a stricter exclusion threshold.

Experiment 2: Transparentizing

Seven of the twenty-one participants returned to the lab during the week following the first experiment. We wished to test whether it is possible to cancel the motormetric effect of delay by correctly choosing the gains of teleoperation channel, as suggested in [14]. The second experiment was similar to the first, but position and force gains were changed. The position gain was calculated individually for each subject such that the motormetric effect of delay would be cancelled. We regressed the amount of overshoot in catch trials as a function of the difference between the levels of linear components of stiffness (k_t) between trained and catch force fields. This allowed us to extract the extent of undershoot Δp in catch trials where the linear stiffness was identical to that in trained trials. We then calculated the position and force gains according to:

$$G_x = (x_t - x_0) / (x_t - x_0 + \Delta p); \quad G_f = 1 / G_x, \quad (2)$$

where x_t is the target position and x_0 is as defined in (1). All other details were identical to experiment 1, including the training phase, test phase, and data analysis.

Experiment 3: Control for learning effects

In order to control for any learning effects that could be responsible for cancelling the effect of delay in experiment 2, we carried out a control experiment. The control subjects performed first experiment 2 and only then experiment 1. Eight subjects performed the experiment with a position gain $G_x = 0.9$ - the median of the position gains of all subjects from experiment 2. Then, six of them returned to the lab in the following day, and performed the experiment with unity gain, as in experiment 1. Two of

the subjects did not return to the lab due to poor performance in the non-delayed condition of the experiment. All other details of both experimental sessions were identical to experiment 1, including the training phase, test phase, and data analysis. In the control experiment, we did not exclude any of the results. Nevertheless, we have verified that the same results are obtained with the exclusion threshold.

4.2 Results

Experiment 1: Motormetric and psychometric effect of delay

Delay caused motormetric underestimation, which was consistent across all nineteen subjects who succeeded in the motormetric task (paired t-test $t_{18}=8.68$, $p=7\times 10^{-8}$). However, in contrast with our previous results [3, 4, 5], there was no change in the psychometric perception of thirteen out of fifteen subjects who succeeded in the motormetric task, and no statistically significant effect across subjects (paired t-test $t_{14}=0.56$, $p=0.5$) as depicted in Fig. 5.

In Fig. 6, trajectories of a typical subject are depicted. The trajectory in Fig. 6A, from a trial within stage 2 of the training phase (linear elastic force fields), supports our assumption that subjects indeed perform typical "slicing" movements [40, 41]. The trajectory in Fig. 6B shows that the general slicing movement is maintained during interaction with the force field; however, the sudden drop of force at the end of the rigid boundary caused transient oscillation in the velocity profile that was suppressed, typically within 100ms.

The motormetric underestimation due to delay is consistent with our previous findings of interaction with linear elastic force fields [6]. The lack of psychometric effect is not in contradiction with our previous experimental results [3, 4, 5], since the absence of the effect can be explained by the same computational model for the perception of stiffness that we suggested in [4]. According to our model, the answers of subjects who are requested to judge the relative stiffness of linear and nonlinear force position relationships could be explained as an outcome of an approximation to a linear force-position function. The result of such approximation strongly depends on the choice of dependent and independent variables. Namely, a linear regression can be performed by assuming that the position information is measured correctly, and minimizing the noise in force - regression of force over position. However, it can be also performed by minimizing the noise in position, assuming that the force is measured exactly - regression of position over force. Perception of stiffness is derived from information about force and position [44]; however, the causality of force and position information in contact with an elastic force field is not defined a-priori, and it can be determined according to the variable that is controlled by the motor system during contact. In [4, 5], we presented a thorough discussion on the implication of our model on a combination of force and position control. The important aspect for our analysis here is that the estimated slope of the linear function is a convex combination of the slope of regression of force

over position (K_{FP}) with the inverse of the slope of regression of position over force (K_{PF}) according to the boundary-crossing ratio. When subjects frequently cross the boundary of the elastic field the weight of K_{PF} is close

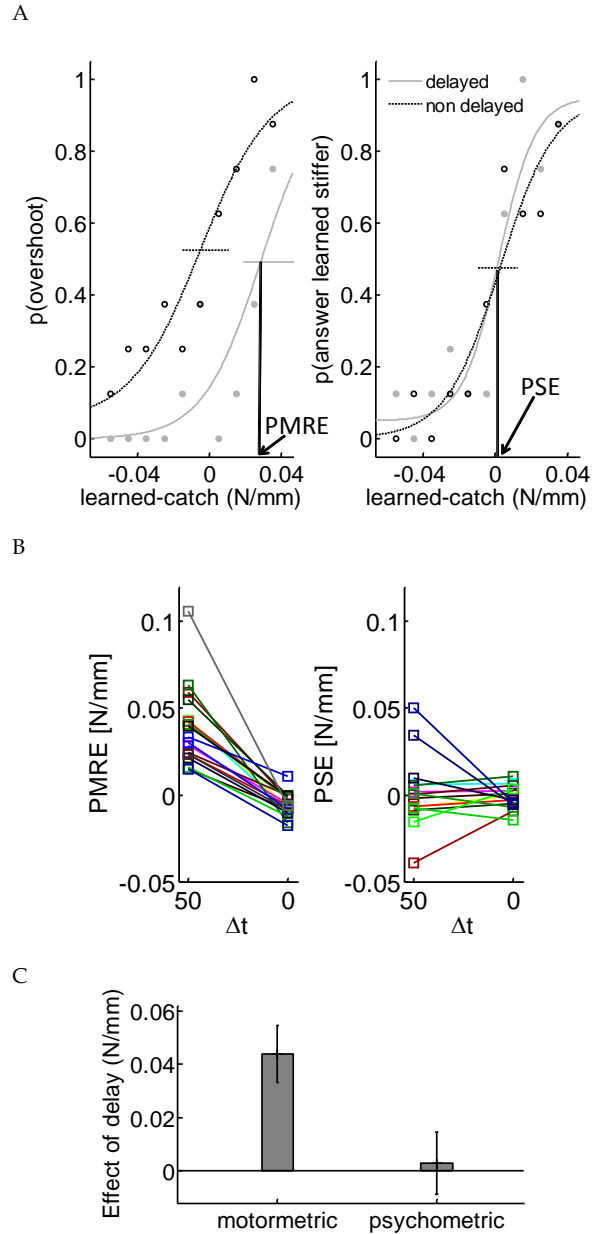

Fig. 5. Experimental results. (A) Example of individual subject's results: motormetric curve (left panel) is shifted to the right, and yields positive PMRE, while there is no shift in psychometric curve, and therefore the PSE is zero. Full gray and empty black circles are the sampled data in delayed and non-delayed trials, respectively. Horizontal bars are 95% confidence intervals for the estimation of PSE/PMRE. (B) Delay caused motormetric underestimation in all subjects' motor performance, as evident by positive PMRE values (left), but no significant change in psychometric perception for all but two subjects, as evident by PSE values clustered around zero (right). PMRE and PSE of the zero delay condition are control, and both are clustered around zero in a similar manner. (C) The overall effect of delay is measured by the difference between task and base PMRE (left) and PSE (right) averaged across subjects. Here, bars show estimation of the mean effect of delay and error bars are 95% confidence intervals for the estimation of the mean.

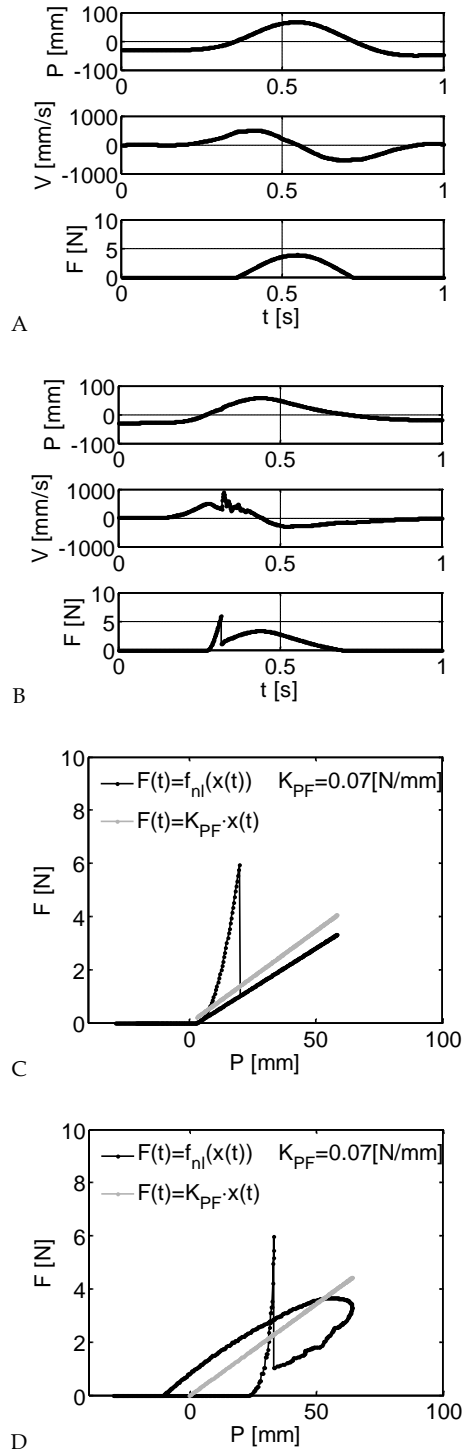

Fig. 6. Example of human-side trajectories from one trial in training phase (A) and two trials in the test phase (B-D). (A-B) Position, velocity, and force as a function of time during interaction with linear elastic force field (A) and nonlinear needle insertion like force field (B). In (B) the sudden drop of forces when "breaking" the rigid boundary caused transient oscillation in the velocity profile, which was suppressed, typically within 100ms. (C-D) Trajectories in force position plane (black) and the linear elastic force field approximation constructed from a regression of position over force information model (gray) in trial without (C) and with (D) delay. Our regression-based model predicts an identical linear force field approximation for both delayed and non-delayed nonlinear force field. (C) is a re-plot of (B) in a force position plane.

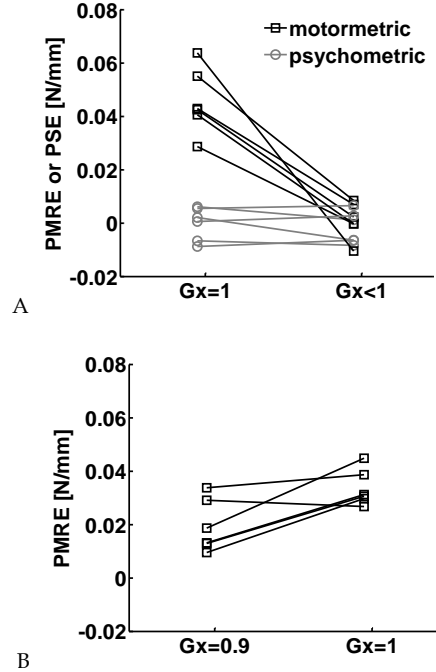

Fig. 7. (A) Successful transparentizing. The PMRE (black squares) and PSE (gray circles) of delayed condition in Experiment 1 (left) and Experiment 2 (right). The motometric effect of delay is cancelled without changing the psychometric lack of effect. (B) Control for learning effects. The PMRE of the delayed condition in first (transparentized, $G_x < 1$, left) and second (regular, $G_x = 1$, right) sessions of experiment 3. The motometric effect of delay is restored in the second session.

to one. Using this model, in our previous study, we successfully explained psychometric overestimation and underestimation of stiffness according to different boundary crossing frequencies. In the current study, subjects start each slicing movement outside the force field, and therefore, the appropriate approximation according to our model is $F(t) = K_{PF}x(t)$, as depicted in Fig. 6C-D. Interestingly, this model predicts identical estimations of delayed and non-delayed nonlinear elastic force fields, in agreement with our experimental findings.

Experiment 2: Transparentizing

Six out of seven subjects who participated in the second experiment succeeded in both motometric and psychometric tasks. By choosing the appropriate position gain for each subject, we have successfully eliminated the motometric effect of delay without changing the psychometric perception of the stiffness of the nonlinear force field. This is depicted in Fig. 7A, where we show only the delayed condition PMRE (black squares) and PSE (gray circles) for unity gain (experiment 1 - left side of Fig. 7A) and for smaller than unity gain (experiment 2 - right side of Fig. 7A).

Experiment 3: Control for learning effects

The PMRE of five out of six subjects increased in the second session, in which the position gain was changed from 0.9 to 1; the PMRE of the sixth subject decreased, but not statistically significantly. Overall, there was a statisti-

cally significant increase in the mean value of PMRE between sessions 1 and 2 (paired t-test $t_5=5.92$, $p=0.002$), but no statistically significant change in PSE (paired t-test $t_5=0.09$, $p=0.93$). Similar to the results of Experiment 1, delay caused motormetric underestimation (paired t-test $t_5=10.5$, $p=10^{-4}$) in the second session, but no statistically significant change in the psychometric perception (paired t-test $t_5=-1$, $p=0.36$). Therefore, we conclude that even if some learning took place between experiments 1 and 2, it was not responsible for cancelling of the motormetric effect. This is evident because direction of change in PMRE reversed when subjects performed reversed temporal order of conditions in Experiment 3. There is a difference between the PMRE values of Experiment 2 and of Experiment 3 session 1, and the channel is not completely transparent in the first session of the control experiment. However, this is not surprising, since in Experiment 2 we calculated individual gains for each subject, whereas in Experiment 3 we used the same gain for all subjects.

5 SIMULATION

In the following section, we present a simulation of a simplified model for the hand and neural controller. This simulation explains our experimental results, and elaborates on additional implications of our psychometric results. Following the procedure described in details in [6], we model the human arm as a planar two link manipulator. The model assumes that the dynamics of the haptic device can be neglected in comparison to a human arm's inertia, and therefore, the simulation concerns only the arm. Accordingly, the dynamic equation is written as:

$$\mathbf{H}(\mathbf{q})\ddot{\mathbf{q}} + \mathbf{C}(\mathbf{q}, \dot{\mathbf{q}})\dot{\mathbf{q}} = \mathbf{Q}(\mathbf{q}, \dot{\mathbf{q}}, \mathbf{q}_d(t)) \quad (3)$$

where $\mathbf{q} = (q_1, q_2)^T$ is a vector of elbow and shoulder joints angles, $\mathbf{H}(\mathbf{q})$ is the inertial matrix, $\mathbf{C}(\mathbf{q}, \dot{\mathbf{q}})$ is the Coriolis and centripetal coefficients matrix, and $\mathbf{Q}(\mathbf{q}, \dot{\mathbf{q}}, \mathbf{q}_d(t))$ are the joints torques generated by the controller as a function of the joints angles and desired joints' angles trajectories $\mathbf{q}_d(t)$. The controller combines a feedforward (inverse model) and feedback (proportional-derivative PD) component; these represent the central neural command and the combined muscle and reflex impedance, respectively. Therefore:

$$\mathbf{Q}(\mathbf{q}, \dot{\mathbf{q}}, \mathbf{q}_d(t)) = \mathbf{H}(\mathbf{q})\ddot{\mathbf{q}}_d(t) + \mathbf{C}(\mathbf{q}, \dot{\mathbf{q}})\dot{\mathbf{q}} - \mathbf{K}_p(\mathbf{q} - \mathbf{q}_d(t)) - \mathbf{K}_d(\dot{\mathbf{q}} - \dot{\mathbf{q}}_d(t)) \quad (4)$$

where K_p and K_d are proportional and derivative gains of the PD feedback controller respectively. We assume a perfect feedforward control model of inertial, Coriolis and centripetal forces. To simulate the interaction with the force field we added an external force at the end-point of the arm, i.e., to the left side of (3):

$$\mathbf{H}(\mathbf{q})\ddot{\mathbf{q}} + \mathbf{C}(\mathbf{q}, \dot{\mathbf{q}})\dot{\mathbf{q}} + \mathbf{J}^T \mathbf{F}_h(\boldsymbol{\alpha}(\mathbf{q})) = \mathbf{Q}(\mathbf{q}, \dot{\mathbf{q}}, \mathbf{q}_d(t)) \quad (5)$$

where \mathbf{J}^T is the transposed Jacobian at the end-point, $\boldsymbol{\alpha}(\mathbf{q}) = x_h$ is calculated according to direct kinematics, and the force field \mathbf{F}_h is calculated according to (1). To simulate the training process, we added a model of non-delayed force field into the forward model of the controller. Namely, we corrected (4) to be:

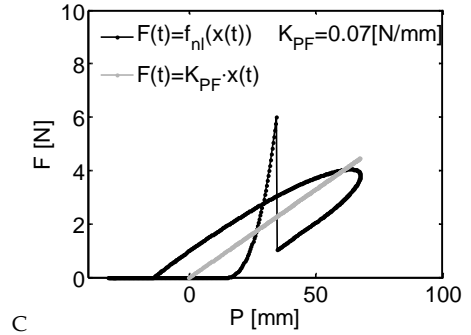
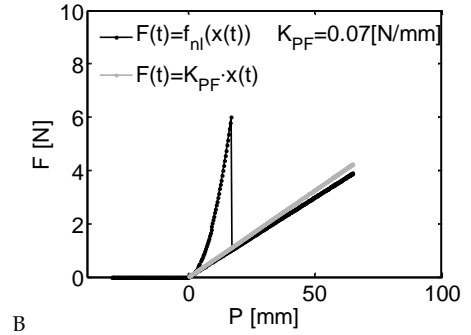
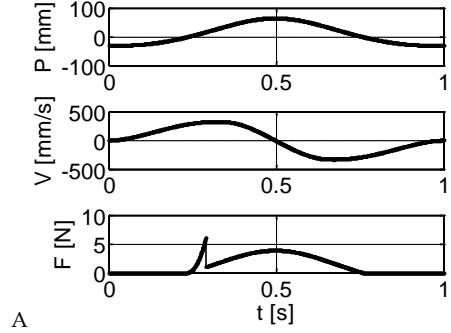

Fig. 8. Simulated trajectories, including the interaction with nonlinear non-delayed force field (A-B), and a nonlinear delayed force field (C). In (A) there is no transient response to the sudden drop in forces since a similar drop is modeled in the forward model as well. (B-C) Trajectories in the force position plane (black) and the linear elastic force field approximation constructed from a regression of position over force information model (gray) in a simulation without (B) and with (C) delay. Our regression-based model predicts identical linear force field approximation for both delayed and non-delayed nonlinear force field.

$$\mathbf{Q}(\mathbf{q}, \dot{\mathbf{q}}, \mathbf{q}_d(t)) = \mathbf{H}(\mathbf{q})\ddot{\mathbf{q}}_d(t) + \mathbf{C}(\mathbf{q}, \dot{\mathbf{q}})\dot{\mathbf{q}} + \mathbf{J}^T \mathbf{F}_h(\boldsymbol{\alpha}(\mathbf{q})) + (-\mathbf{K}_p(\mathbf{q} - \mathbf{q}_d(t)) - \mathbf{K}_d(\dot{\mathbf{q}} - \dot{\mathbf{q}}_d(t))) \quad (6)$$

The desired joint angles trajectory was calculated using the inverse kinematics of an endpoint slicing movement. We modeled the slicing movement as a shifted concatenation of two fifth-order polynomials that represent two reaching movements - to and from the target. Each of these movements was derived by minimizing the jerk [39].

In order to explain our experimental results, we modeled the interaction with nonlinear elastic force field with $k_{b1}=0.02\text{N/mm}$, $k_{b2}=0.02\text{N/mm}^2$, and $k_f=0.06\text{N/mm}$, and total delay of either 0 or 50ms. For the forward model,

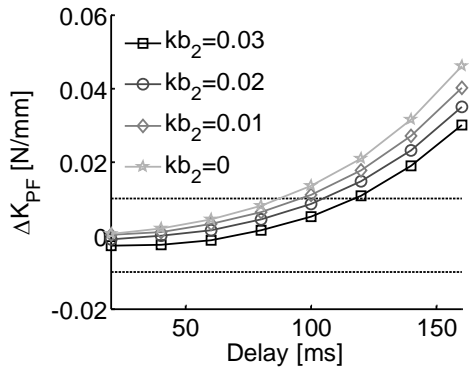

Fig. 9. The difference in perceived stiffness according to a model based on the inverse of the slope of regression of position over force between nonlinear field with and without delay as a function of delay and magnitude of forces in the nonlinear rigid boundary region. Dashed lines represent the region within which a psychometric effect is not expected. Minimal delay for observing psychometric effect increases with increasing forces at the rigid boundary

similar parameters were used, but the delay was always zero. The simulated trajectories are depicted in Fig. 8. These trajectories clearly resemble the experimental trajectories (compare Fig. 6 and 8).

To address the motormetric effect of delay, in a simulation with a 50ms delay, we changed the stiffness of k_t in the forward model such that the slicing movement ended exactly at the target. This was achieved at $k_t=0.04$. Thus, the simulation is consistent with the motormetric underestimation of the stiffness of needle-insertion-like delayed force field.

To explore the psychometric effect, we performed an analysis that is similar to our analysis of experimental trajectories: we fitted a regression-based linear model for the simulated trajectories. In Fig. 8B and C, the linear approximation according to the K_{PF} model is shown. In agreement with the experimental trajectories, the simulated trajectories predict the absence of psychometric effect of delay.

A qualitative examination of the force-position trajectories in Fig. 6 and 8 suggests that the high nonlinear force region masks the distorting effect of delay, without impairment of the discrimination ability. To explore further the interaction between the strength of forces at the nonlinear part and the delay, we repeated the simulation for different levels of k_{b2} and different delays. We calculated the difference between K_{PF} values that were fitted to the simulated trajectories in delayed and non-delayed force fields. We expected to observe psychometric effects whenever this difference was higher than 0.01N/mm. This value was chosen since it is the JND for standard stiffness level of 0.06N/mm according to Weber fraction of 15%. We chose the value of 15% because it is the mean of different values that were reported in the literature [44, 45, 46, 47]. The results are depicted in Fig. 9, and it is evident that the minimal delay for observing psychometric effect increases with increasing forces at the rigid boundary.

There are several limitations to our simulation analysis. First, the trajectory in force position plane depends on

additional factors, such as velocity and extent of penetration. Second, the model that we used for the dynamics and the control of the arm is highly simplified. Finally, our regression-based model is not the only possible model for predicting the answers of human subjects regarding the stiffness of force fields. Therefore, the predictions from the presented simulation study should be considered only qualitatively, and the minimal delay for effect on perception must be determined experimentally for each model of surgical simulation.

6 DISCUSSION

In this study, we explored the effect of delay on perception and action in a simulated needle insertion task. We showed that delay causes motormetric underestimation of the stiffness of a force field that emulates needle insertion, but does not change the cognitive perception. A simulation of a simplified mechanical model of the arm and neural controller, in which we used the inverse of the slope of regression of position over force data as a model for perception, supports these experimental results. Moreover, we show that by appropriately choosing a position gain and reciprocal force gain of a teleoperation channel it is possible to cancel the motormetric effect of delay without changing the psychometric perception of the stiffness of nonlinear force field.

The different motormetric and psychometric effects of delay demonstrate a gap between perception and action. This gap supports our suggestion [14] that transparency of teleoperation systems in general, and telesurgery systems in particular, should be assessed using multidimensional transparency measures that include perceptual as well as motor components. Moreover, a focus on these two components is critical for additional aspects in surgery, such as training surgeons and skills evaluation. For example, it was shown that stiffness perception in the context of veterinary medicine is a learned clinical skill, and it was suggested as a criterion for the evaluation of improvement during training [48].

The simulation study predicts that the psychometric effect of delay is partially masked by the rigid nonlinear boundary. According to this study, at around 100ms delay, the detection of effect of delay depends on the magnitude of forces in the rigid boundary region. Our experimental results suggest that such transition indeed occurs, albeit at smaller delays - at around 50ms. In previous studies with $k_{b2}=0$ we observed a clear psychometric effect [3, 4, 5], while no such effect was detected in the current study where $k_{b2}=0.02\text{N/mm}^2$. This is consistent with the findings in [29] where delay of 54ms was identified as critical for detection of delay effects. In this study the force profile was similar to the nonlinear part of our force field, but downscaled, such that maximum force was 4N, equivalent to $k_{b2}=0.01\text{N/mm}^2$. In a different study, tolerance to 30-35ms delay was reported for virtual soft walls [49]. To get a clearer view of this point, the detailed predictions in Fig. 9 can be tested experimentally; for example, it would be interesting to explore whether for different delays the psychometric effect of delay disappears

with different magnitudes of nonlinear rigid component of the boundary. Even more importantly, however, this result leads to the conclusion that the effect of delay must be examined for each surgical task and for each type of tissue experimentally. That is, a certain delay might be perceptually and/or functionally insignificant for one task, but distorting and disturbing for another.

In the current study, we explored simulated, rather than real, needle insertion. Thus, the study falls into a general class of studies, where interaction with a haptic device emulates interaction with environments with nonlinear force-position characteristics. Nonlinear force-position relations were used in previous studies in order to explore the human motor system. For example, in [50], zero, linear, quadratic, and cubic force field were applied with the aim of exploring whether the human operator uses position, force, or combined control during interaction with a virtual force field. In [51], a nonlinear stiffness was used in order to explore the weighting of the force and position within the proprioceptive system during interaction with an environment with known stiffness. In [5] we discuss more fully the combination of force and position in the motor system. Stepwise-linear force-position [52] and force-velocity [53] relations were used to study various aspects of human perception and action. Using simulated, rather than real environments provides us with the ability to explore each component separately, whether it is delay [3, 4, 5, 6], nonlinearity [15], or a combination of both.

Future studies are needed to quantify the effects of delay on perception and action in other clinically relevant surgical procedures, such as cutting, suturing, and cautery. In general, complex motor tasks with more than one single reversal point are important for proper evaluation of the motor transparency. These should be explored more systematically for designing a practical transparentizing procedure. Based on the simulated results of the current study, such exploration should be performed experimentally for each typical movement, and for various types of mechanical environments.

The results presented here provide initial, but promising steps towards achieving efficient and transparent teleoperation and telesurgery.

ACKNOWLEDGMENT

The authors wish to thank Annabel Sharon and Amit Milstein for their help in collecting the experimental data. This work was supported by the Binational United States Israel Science Foundation and by NINDS grants 2R01NS035673. IN is supported by the Kreitman and Clore fellowships.

REFERENCES

- [1] P.G. Schulam, S.G. Docimo, W. Saleh, C. Breitenbach, R.G. Moore, and L. Kavoussi, "Telesurgical Mentoring," *Surgical Endoscopy*, vol. 11, pp. 1001-1005, 1997.
- [2] J. Marescaux, J. Leroy, M. Gagner, F. Rubino, D. Mutter, M. Vix, S.E. Butner, and M.K. Smith, "Transatlantic Robot-Assisted Telesurgery," *Nature*, vol. 413, pp. 379-380, 2001.
- [3] A. Pressman, L.H. Welty, A. Karniel, and F.A. Mussa-Ivaldi, "Perception of Delayed Stiffness," *The international Journal of Robotics Research*, vol. 26, pp. 1191-1203, 2007.
- [4] I. Nisky, F.A. Mussa-Ivaldi, and A. Karniel, "A Regression and Boundary-Crossing-Based Model for the Perception of Delayed Stiffness," *Haptics, IEEE Transactions on*, vol. 1, pp. 73-82, 2008.
- [5] I. Nisky, P. Baraduc, and A. Karniel, "Proximodistal Gradient in the Perception of Delayed Stiffness," *Journal of Neurophysiology*, vol. 103, pp. 3017-3026, 2010.
- [6] A. Pressman, I. Nisky, A. Karniel, and F.A. Mussa-Ivaldi, "Probing Virtual Boundaries and the Perception of Delayed Stiffness," *Advanced Robotics*, vol. 22, pp. 119-140, 2008.
- [7] M.A. Goodale and A.D. Milner, "Separate Visual Pathways for Perception and Action," *Trends in Neurosciences*, vol. 15, pp. 20-25, 1992.
- [8] T. Ganel and M.A. Goodale, "Visual Control of Action but Not Perception Requires Analytical Processing of Object Shape," *Nature*, vol. 426, pp. 664-667, 2003.
- [9] D.P. Carey, "Do Action Systems Resist Visual Illusions?," *Trends in Cognitive Sciences*, vol. 5, pp. 109-113, 2001.
- [10] G. Niemeyer and J.J.E. Slotine, "Telemanipulation with Time Delays," *International Journal of Robotics Research*, vol. 23, pp. 873-890, 2004.
- [11] D.A. Lawrence, "Stability and Transparency in Bilateral Teleoperation," *IEEE Transactions on Robotics and Automation*, vol. 9, pp. 624-627, 1993.
- [12] N. Abolhassani, R. Patel, and M. Moallem, "Needle Insertion into Soft Tissue: A Survey," *Medical Engineering & Physics*, vol. 29, pp. 413-431, 2007.
- [13] A.M. Okamura, C. Simone, and M.D. O'Leary, "Force Modeling for Needle Insertion into Soft Tissue," *Biomedical Engineering, IEEE Transactions on*, vol. 51, pp. 1707-1716, 2004.
- [14] I. Nisky, F.A. Mussa-Ivaldi, and A. Karniel, "Perceptuo-Motor Transparency in Bilateral Teleoperation," in *9th biennial ASME conference on engineering systems design and analysis ESDA2008*, Haifa, Israel, 2008, pp. 449-456.
- [15] I. Nisky, A. Pressman, C.M. Pugh, F.A. Mussa-Ivaldi, and A. Karniel, "Perception and Action in Simulated Telesurgery," in *EuroHaptics 2010*, Amsterdam, Netherlands, 2010, pp. 213-218.
- [16] K.B. Fite, J.E. Speich, and M. Goldfarb, "Transparency and Stability Robustness in Two-Channel Bilateral Telemanipulation," *Journal of Dynamic Systems, Measurement, and Control*, vol. 123, pp. 400-407, 2001.
- [17] K. Hashtrudi-Zaad and S.E. Salcudean, "Transparency in Time-Delayed Systems and the Effect of Local Force Feedback for Transparent Teleoperation," *IEEE Transactions on Robotics and Automation*, vol. 18, pp. 108-114, 2002.
- [18] Y. Yokokohji and T. Yoshikawa, "Bilateral Control of Master-Slave Manipulators for Ideal Kinesthetic Coupling-Formulation and Experiment," *Robotics and Automation, IEEE Transactions on*, vol. 10, pp. 605-620, 1994.
- [19] N. Chopra, M.W. Spong, R. Ortega, and N.E. Barabanov, "On Position Tracking in Bilateral Teleoperation," in *Proceedings of the 2004 American Control Conference* Boston, Massachusetts, 2004, pp. 5244-5249.
- [20] S. Hirche, A. Bauer, and M. Buss, "Transparency of Haptic Telepresence Systems with Constant Time Delay," in *proceedings of 2005 IEEE Conference on Control Applications*, 2005, pp. 328-333.
- [21] B. Hannaford, "Stability and Performance Tradeoffs in Bilateral Telemanipulation," in *IEEE International Conference on Robotics and Automation*, Scottsdale, AZ; USA, 1989, pp. 1764-1767.
- [22] G. De Gerssem, H. Van Brussel, and F. Tendick, "Reliable and Enhanced Stiffness Perception in Soft-Tissue Telemanipulation,"

- The International Journal of Robotics Research*, vol. 24, pp. 805-822, 2005.
- [23] S. Aglioti, J.F.X. DeSouza, and M.A. Goodale, "Size-Contrast Illusions Deceive the Eye but Not the Hand," *Current Biology*, vol. 5, pp. 679-685, 1995.
- [24] M.A. Goodale and G.K. Humphrey, "The Objects of Action and Perception," *Cognition*, vol. 67, pp. 181-207, 1998.
- [25] M. Gentilucci and A. Negrotti, "Dissociation between Perception and Visuomotor Transformation During Reproduction of Remembered Distances," *J Neurophysiol*, vol. 72, pp. 2026-2030, 1994.
- [26] R. Shadmehr and F.A. Mussa-Ivaldi, "Adaptive Representation of Dynamics During Learning of a Motor Task," *Journal of Neuroscience*, vol. 14, pp. 3208-3224, 1994.
- [27] Y.C. Fung, "Elasticity of Soft Tissues in Simple Elongation," *American Journal of Physiology*, vol. 213, pp. 1532-1544, 1967.
- [28] S.P. DiMaio and S.E. Salcudean, "Needle Insertion Modeling and Simulation," *Robotics and Automation, IEEE Transactions on*, vol. 19, pp. 864-875, 2003.
- [29] L.M. Batteau, A. Liu, J.B.A. Maintz, Y. Bhasin, and M.W. Bowyer, "A Study on the Perception of Haptics in Surgical Simulation," in *Medical Simulation*. vol. 3078, ed: Springer Berlin / Heidelberg, 2004, pp. 185-192.
- [30] J. Duncan, G. Gerig, J.R. Crouch, C.M. Schneider, J. Wainer, and A.M. Okamura, "A Velocity-Dependent Model for Needle Insertion in Soft Tissue," in *Medical Image Computing and Computer-Assisted Intervention – Miccai 2005*. vol. 3750, ed: Springer Berlin / Heidelberg, 2005, pp. 624-632.
- [31] B. Maurin, L. Barbe, B. Bayle, P. Zanne, J. Gangloff, M. De Mathelin, and A. Gangi, "In Vivo Study of Forces During Needle Insertions," in *Proceedings of the scientific workshop on medical robotics, navigation and visualization (MRNV)*. , 2004, pp. 415-422.
- [32] A. Kerdok, M. Ottensmeyer, and R. Howe, "Effects of Perfusion on the Viscoelastic Characteristics of Liver," *Journal of Biomechanics*, vol. 39, pp. 2221-2231, 2006.
- [33] J. Kim, B. Tay, N. Stylopoulos, D.W. Rattner, and M.A. Srinivasan, "Characterization of Intra-Abdominal Tissues from in Vivo Animal Experiments for Surgical Simulation," in *Medical Image Computing and Computer-Assisted Intervention - Miccai 2003*. vol. 2878, ed: Springer Berlin / Heidelberg, 2003, pp. 206-213.
- [34] J. Rosen, B. Hannaford, M.P. MacFarlane, and M.N. Sinanan, "Force Controlled and Teleoperated Endoscopic Grasper for Minimally Invasive Surgery-Experimental Performance Evaluation," *Biomedical Engineering, IEEE Transactions on*, vol. 46, pp. 1212-1221, 1999.
- [35] A. Liu, F. Tendick, K. Cleary, and C. Kaufmann, "A Survey of Surgical Simulation: Applications, Technology, and Education," *Presence: Teleoperators and Virtual Environments*, vol. 12, pp. 599-614, 2003.
- [36] M.J. Kim, E.-K. Kim, S.I. Park, B.M. Kim, J.Y. Kwak, S.J. Kim, J.H. Youk, and S.H. Park, "Us-Guided Fine-Needle Aspiration of Thyroid Nodules: Indications, Techniques, Results.," *RadioGraphics*, vol. 28, pp. 1869-1886, 2008.
- [37] A. Renshaw and N. Pinnar, "Comparison of Thyroid Fine-Needle Aspiration and Core Needle Biopsy," *American Journal of Clinical Pathology*, vol. 128, pp. 370-374, 2007.
- [38] R. Erickson, L. Sayage-Rabie, and R. Beissner, "Factors Predicting the Number of Eus-Guided Fine-Needle Passes for Diagnosis of Pancreatic Malignancies," *Gastrointestinal Endoscopy*, vol. 51, pp. 184-190, 2000.
- [39] T. Flash and N. Hogan, "The Coordination of Arm Movements: An Experimentally Confirmed Mathematical Model.," *Journal of Neuroscience*, vol. 5, pp. 1688-1703, 1985.
- [40] R.A. Scheidt and C. Ghez, "Separate Adaptive Mechanisms for Controlling Trajectory and Final Position in Reaching," *Journal of Neurophysiology*, vol. 98, pp. 3600-3613, December 1, 2007.
- [41] G.L. Gottlieb, "Muscle Activation Patterns During Two Types of Voluntary Single-Joint Movement," *Journal of Neurophysiology*, vol. 80, pp. 1860-1867, 1998.
- [42] F.A. Wichmann and N.J. Hill, "The Psychometric Function: I. Fitting, Sampling, and Goodness of Fit," *Perception & Psychophysics*, vol. 63, pp. 1293-1313, Nov 2001.
- [43] F.A. Wichmann and N.J. Hill, "The Psychometric Function: Ii. Bootstrap-Based Confidence Intervals and Sampling," *Perception & Psychophysics*, vol. 63, pp. 1314-1329, Nov 2001.
- [44] L.A. Jones and I.W. Hunter, "A Perceptual Analysis of Stiffness," *Experimental Brain Research*, vol. 79, pp. 150-156, 1990.
- [45] H.Z. Tan, N.I. Durlach, G. Beauregard, and M.A. Srinivasan, "Manual Discrimination of Compliance Using Active Pinch Grasp: The Roles of Force and Work Cues," *Perception & Psychophysics*, vol. 57, pp. 495-510, 1995.
- [46] H.Z. Tan, X.D. Pang, and N.I. Durlach, "Manual Resolution of Length, Force, and Compliance," presented at the DSC Advances in robotics, 1992, Anaheim, California., 1992.
- [47] L. Nicholson, R. Adams, and C. Maher, "Reliability of a Discrimination Measure for Judgements of Non-Biological Stiffness," *Manual Therapy*, vol. 2, pp. 150-156, 1997.
- [48] N. Forrest, S. Baillie, and H.Z. Tan, "Haptic Stiffness Identification by Veterinarians and Novices: A Comparison," in *Third Joint EuroHaptics conference, 2009 and Symposium on Haptic Interfaces for Virtual Environment and Teleoperator Systems. World Haptics 2009*. , 2009, pp. 646-651.
- [49] S. Okamoto, M. Konyo, S. Saga, and S. Tadokoro, "Detectability and Perceptual Consequences of Delayed Feedback in a Vibrotactile Texture Display," *IEEE Transactions on Haptics*, vol. 2, pp. 73-84, 2009.
- [50] D.W. Repperger, C.A. Phillips, and T.L. Chelette, "A Study on Spatially Induced "Virtual Force" with an Information Theoretic Investigation of Human Performance," *Systems, Man and Cybernetics, IEEE Transactions on*, vol. 25, pp. 1392-1404, 1995.
- [51] W. Mugge, J. Schuurmans, A.C. Schouten, and F.C.T. van der Helm, "Sensory Weighting of Force and Position Feedback in Human Motor Control Tasks," *Journal of Neuroscience*, vol. 29, pp. 5476-5482, 2009.
- [52] R. Leib, I. Nisky, and A. Karniel, "Perception of Stiffness During Interaction with Delay-Like Nonlinear Force Field," in *Haptics: Generating and Perceiving Tangible Sensations*. vol. 6191, A. Kappers, et al., Eds., ed: Springer Berlin / Heidelberg, 2010, pp. 87-92.
- [53] P.A. Millman and J.E. Colgate, "Effects of Nonuniform Environment Damping on Haptic Perception and Performance of Aimed Movements," in *ASME Dynamic Systems and Control Division*, 1995, pp. 703-711.

Ilana Nisky received her B.Sc. (summa cum laude) and M.Sc. (summa cum laude) from the Department of Biomedical Engineering, Ben-Gurion University of the Negev, Israel, in 2006 and 2009 respectively, and is currently studying towards a Ph.D. (direct track) in biomedical engineering. Ms. Nisky received the Wolf Foundation scholarship for undergraduate and graduate students, Zlotowski and Ben-Amitai prizes for excellent graduate research, and she is currently a Kreitman Foundation fellow and Clore scholar. Her research interests include motor control, haptics, robotics, human and machine learning, teleoperation, and human-machine interfaces. She is

a member of the Society for the Neural Control of Movement, the Society for Neuroscience, and Technical Committee on Haptics.

Assaf Pressman received his B.Sc. degree in 1998 and the M.Sc. degree in 2001 in Electrical Engineering from Ben-Gurion University of the Negev. During his undergraduate studies he worked for Applied Materials Corporation, Rehovot, Israel. From 2000-2002 Pressman worked in Widemed, (Omer, Israel) developing algorithms for automatic sleep apnea identification. From 2002-2004 he worked as a system engineer and algorithm developer in the Israel Aircraft industry (Ashdod, Israel). Since 2004 he has been in the Robotics laboratory at the Sensory Motor Performance Program, Rehabilitation Institute of Chicago, Chicago IL. Currently, he is enrolled in the PhD program in the Department of Biomedical Engineering at Ben-Gurion University of the Negev. His research interests include Brain Theory, Biomedical Signal Processing, Motor Control and Motor Learning. He is a member of the Society for the Neural Control of Movement, and the Society for Neuroscience.

Carla M. Pugh received her B.A. degree in 1988 from University of California Berkeley and her M.D. degree from Howard University in 1992. Upon completion of her surgical training at Howard University Hospital in 1997, she went to Stanford University and received a PH.D. in education, 2001. In 2003, Dr. Pugh became assistant professor of surgery at Northwestern University and was promoted to associate professor in 2010. She is director of Northwestern's Center for Advanced Surgical Education and holds an adjunct professorship in Northwestern's school of education and social policy. Dr. Pugh has been an invited editor on a number of medical and engineering journals and serves on committees for the American College of Surgeons, Association for Academic Surgery and Medicine Meets Virtual Reality. Dr. Pugh's work has been recognized in *Wired Magazine*, *New York Times*, *Reuters*, *BBC News*, *Chicago Sun Times* and *National Public Radio*. Her research is grounded in a special interest in the use of sensors and data acquisition technology for assessing hands-on clinical skills. As a graduate student, she developed her first training tool using this technology and was awarded a method patent by the United States Patent Office. Dr. Pugh has received numerous grant awards for her work and is the recent recipient of a National Institutes of Health R-01. This funding will be used to validate one of her sensorized training models for high stakes clinical examination skills.

Ferdinando A. Mussa-Ivaldi is a member of the IEEE. He holds a degree (Laurea) in physics from the University of Torino (1978) and a PhD in biomedical engineering from the Politecnico di Milano (1987). He is Professor of Physiology, Physical medicine and Rehabilitation and Biomedical Engineering at Northwestern University. Dr. Mussa-Ivaldi is Senior Research Scientist at the Rehabilitation Institute of Chicago, where he founded and directs the Robotics Laboratory. His areas of interest and expertise include robotics, neurobiology of the sensory-motor system and computational neuroscience. Among Prof. Mussa-Ivaldi's achievements are: the first measurement of human arm multi-joint impedance; the development of a technique for investigating the mechanisms of motor learning through the application of deterministic force fields; the discovery of a family of integrable generalized inverses for redundant kinematic chains; the discovery of functional modules within the spinal cord that generate a discrete family of force-fields; the development of a theoretical framework for the representation, generation and learning of limb movements; and the development of the first neurobotic system in which the brainstem of a lamprey controls the behavior of a mobile-robot through a closed-loop interaction. Dr. Mussa-Ivaldi has 110 full-length publications and 85 abstracts. He serves on the editorial boards of the *Journal of Neural Engineering* and *The Journal of Motor Behavior* and is member of the Society for Neuroscience and of the Society for the Neural Control of Movement.

Amir Karniel was born in Jerusalem, Israel in 1967. He received a B.Sc. degree (Cum Laude) in 1993, a M.Sc. degree in 1996, and a Ph.D. degree in 2000, all in Electrical Engineering from the Technion-Israel Institute of Technology, Haifa, Israel. He served four years in the Israeli Navy as an electronics technician and worked during his undergraduate studies at Intel Corporation, Haifa, Israel. Dr. Karniel received the E. I. Jury award for excellent students in the area of systems theory, and the Wolf Scholarship award for excellent research students. For two years he had been a post doctoral fellow

at the department of physiology, Northwestern University Medical School and the Robotics Lab of the Rehabilitation Institute of Chicago. Since 2003, he is with the Department of Biomedical Engineering at Ben-Gurion University of the Negev where he serves as the head of the Computational Motor Control Laboratory and the organizer of the annual International Computational Motor Control Workshop. In the last few years, his studies are funded by awards from the Israel Science Foundation, the Binational United-States Israel Science Foundation, the National Institute of Psychobiology in Israel, and the US-AID Middle East Research Collaboration. Dr. Karniel is on the Editorial board of the IEEE Transactions on System Man and Cybernetics Part A, *The Frontiers in Neuroscience*, and a guest Editor for a special issue of the IEEE Transactions on Haptics. His research interests include Human Machine interfaces, Haptics, Brain Theory, Motor Control and Motor Learning.