

Feedforward Control

Objectives of the Chapter

- Describe how to use feedforward control to compensate for measured disturbances.
- Show how to use the material in chapters 3, 4, 6, and 7 to design and tune combined feedforward/feedback control systems.

Prerequisite Reading

Chapter 3, “One-Degree of Freedom Internal Model Control”

Chapter 4, “Two-Degree of Freedom Internal Model Control”

Chapter 6, “PI and PID Controller Parameters from IMC Designs”

Chapter 7, “Tuning and Synthesis of 1DF IMC Controllers for Uncertain Processes”

9.1 INTRODUCTION

Combined feedforward plus feedback control can significantly improve performance over simple feedback control whenever there is a major disturbance that can be measured before it affects the process output. In the most ideal situation, feedforward control can entirely eliminate the effect of the measured disturbance on the process output. Even when there are modeling errors, feedforward control can often reduce the effect of the measured disturbance on the output better than that achievable by feedback control alone. However, the decision as to whether or not to use feedforward control depends on whether the degree of improvement in the response to the measured disturbance justifies the added costs of implementation and maintenance. The economic benefits of feedforward control can come from lower operating costs and/or increased salability of the product due to its more consistent quality.

Feedforward control is always used along with feedback control because a feedback control system is required to track setpoint changes and to suppress unmeasured disturbances that are always present in any real process.

Figure 9.1a gives the traditional block diagram of a feedforward control system (Seborg et al., 1989). Figure 9.1b shows the same block diagram, but redrawn so as to show clearly that the feedforward part of the control system does not affect the stability of the feedback system and that each system can be designed independently. Figure 9.2 shows a typical application of feedforward control. The continuously stirred tank reactor is under feedback temperature control. Feedforward control is used to rapidly suppress feed flow rate disturbances.

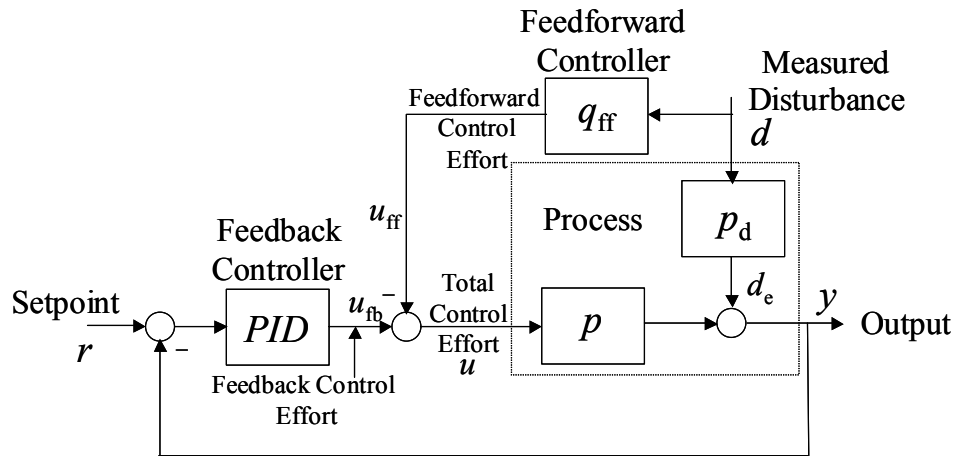

Figure 9.1a Traditional feedforward/feedback control structure.

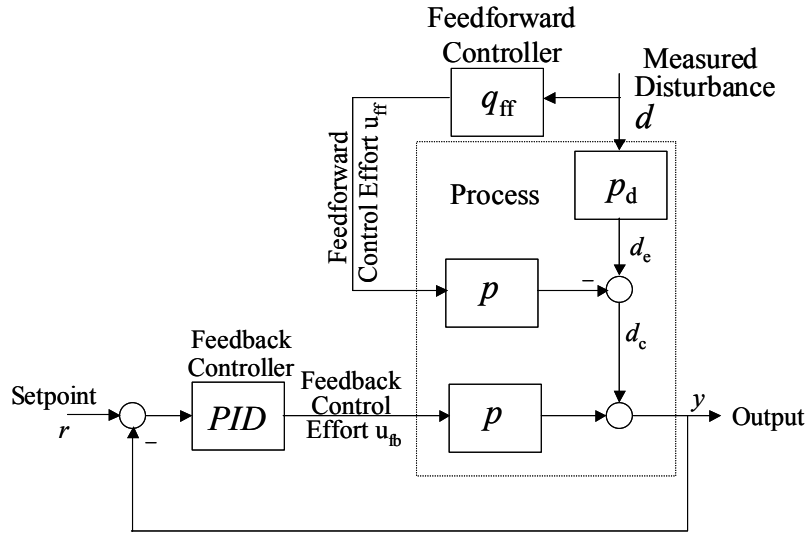

Figure 9.1b Block diagram equivalent to that of Figure 9.1a.

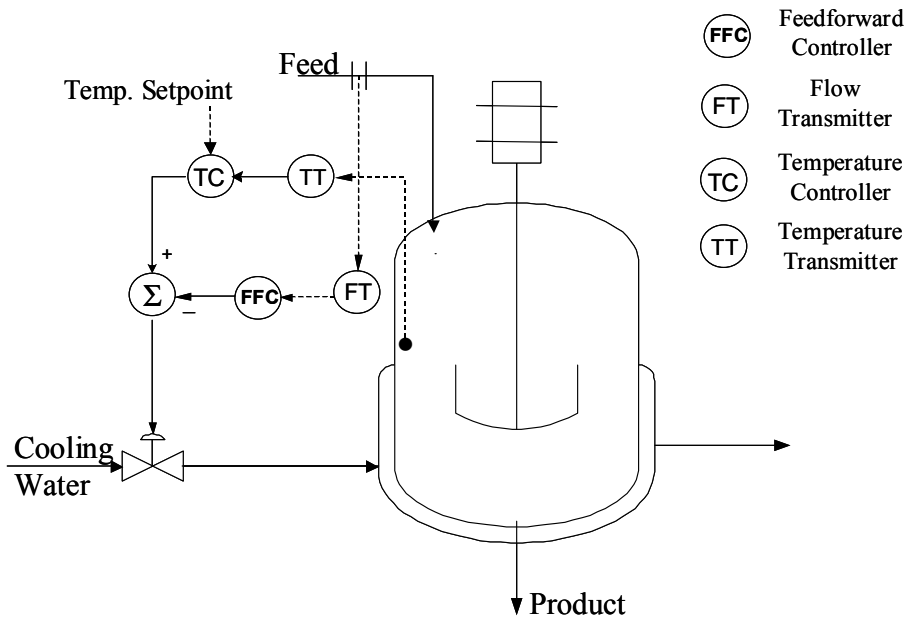

Figure 9.2 Feedforward control on the feed to a continuously stirred tank reactor operating under reactor temperature control.

9.2 CONTROLLER DESIGN WHEN PERFECT COMPENSATION IS POSSIBLE

The transfer function between the process output y and the measured disturbance d from Figure 9.1b is

$$y(s) = \frac{d_c}{1 + PID * p} = \frac{(p_d - pq_{ff})d}{1 + PID * p}. \quad (9.1)$$

To eliminate the effect of the measured disturbance, we need only choose q_{ff} so that

$$p_d - pq_{ff} = 0. \quad (9.2)$$

If the deadtime and relative order of p_d are both greater than those of p , and p has no right half plane zeros, then q_{ff} can be chosen as

$$q_{ff} = \tilde{p}^{-1} \tilde{p}_d. \quad (9.3)$$

As in previous chapters, a \sim over a process transfer function indicates that it is a model of the process.

Even in the above case, where the feedforward controller can perfectly compensate the measured disturbance, it may not pay to implement a feedforward controller when the process p is well approximated as a minimum phase system (i.e., one that contains no deadtime or right half plane zeros). In this case, it is usually possible to design a 1DF or 2DF PID controller to suppress disturbances well enough so that there is little to be gained by the addition of feedforward control (Morari and Zafiriou, 1989).

Whenever the relative order of $\tilde{p}_d(s)$ is less than or equal to that of $\tilde{p}(s)$, then the noise amplification can be reduced by adding a filter, as in the design of an IMC controller, so that Eq. (9.3) becomes:

$$q_{ff} = \tilde{p}^{-1} \tilde{p}_d f; \quad f \equiv 1/(\varepsilon s + 1)^r \quad (9.4)$$

The order r of the filter f is either the relative order of $\tilde{p}_d^{-1} \tilde{p}(s)$ or 0 if the relative order of $\tilde{p}_d^{-1} \tilde{p}(s)$ is equal or less than zero. The filter time constant ε is chosen to limit noise amplification, just as was done for IMC controllers for perfect models (see Chapter 3).

The PID controller in Figure 9.1 can be designed and tuned as either a 1DF or 2DF controller using the techniques of chapters 6, 7, and 8 without regard to the addition of a feedforward controller. Most often, however, the unmeasured disturbances are not severe enough to justify the added complication of a 2DF PID controller.

9.3 CONTROLLER DESIGN WHEN PERFECT COMPENSATION IS NOT POSSIBLE

When the deadtime in the disturbance lag p_d is less than that of the control effort lag p , then the feedforward controller q_{ff} , given by Eq. (9.4), is not realizable. In this case, perfect compensation is no longer possible. Much of the literature suggests designing the feedforward controller by simply dropping the unrealizable part of the controller, as is done for a single-degree of freedom IMC controller. However, as we shall soon see by example, the foregoing is by no means the best design. A better feedforward controller can be obtained using a 2DF design. To see why this is, we rewrite the expression for the net effect of the measured disturbance on the output from Eq. (9.1) as

$$d_c = (1 - pq_{ff}p_d^{-1})p_d d = (1 - pq_{ff}p_d^{-1})d_e. \quad (9.5)$$

Since, by assumption, the term pp_d^{-1} contains a deadtime, there is no realizable choice of the feedforward controller q_{ff} that makes the term in brackets in Eq. (9.5) zero. Therefore, there will be a long tail to the response of d_c to a step disturbance d if the lag of p_d is on the order of, or larger than, the lag of p , unless q_{ff} is chosen so that the zeros of $(1 - \tilde{p}q_{ff}\tilde{p}_d^{-1})$ cancel the poles of \tilde{p}_d . The procedure for such a choice of q_{ff} is the same as that described in Chapter 4, except that here, the model is $\tilde{p}\tilde{p}_d^{-1}$ rather than just \tilde{p} , as in the design of 2DF feedback controllers. Indeed, the 2DF controller design capability of IMCTUNE can be used to determine q_{ff} . To illustrate, we return to Example 8.1, except now the disturbance is measured and there is a deadtime of 0.5 time units before the disturbance enters the disturbance lag.

Example 9.1 Comparison of 1DF and 2DF Feedforward Controller Designs

The purpose of this example is to compare the performance of 1DF and 2DF feedforward controllers when the process models are perfect. The process is

$$\tilde{p}(s) = p(s) = e^{-s}/(s+1); \quad \tilde{p}_d(s) = p_d(s) = e^{-0.5s}/(4s+1). \quad (9.6)$$

For the above system, the 1DF and 2DF feedforward controllers from IMCTUNE, and from equations (9.3) and (9.5) are

$$q_{ff}(s) = (s+1)/(4s+1), \quad (9.7a)$$

$$q_{ff}(s) = (s+1)(.473s+1)/(4s+1)(0.006s+1). \quad (9.7b)$$

Notice that the 1DF controller, Eq. (9.7a), does not need a filter, as it is already a lag that does not amplify noise. The 2DF controller, Eq. (9.7b), satisfies the requirement that

$(1 - \tilde{p}q_{ff}\tilde{p}_d^{-1})$ cancel the poles of \tilde{p}_d . Only a small filter time constant of 0.006 is needed to reduce the controller noise amplification to 20 because of the relatively large disturbance lag. To obtain Eq. (9.7b) from IMCTUNE, we entered the process model as $\tilde{p}\tilde{p}_d^{-1} = (4s+1)e^{-.5s}/(s+1)$ and the model “disturbance” lag as $(4s+1)$. The part of the model to invert is taken as $(4s+1)/(s+1)$, and the order of the controller filter is set to zero. Entering a filter time constant of 0.006 yields Eq. (9.7b).

Figures 9.3 and 9.4 compare the responses of the process output with and without feedback, using the IDF and 2DF controllers given by equations (9.7a) and (9.7b). The output y , when the feedback loop is open, is the same as the compensated disturbance signal d_c , shown in Figure 9.1b and defined by Eq. (9.5). Notice that the addition of the feedback system improves the response of the output using a 1DF feedforward controller, but degrades the output response using a 2DF feedforward controller. The reason for the degradation in response is that the PID controller attempts to suppress the pulse d_c , created by the feedforward control system. Of course it cannot, and the attempt creates another pulse in the opposite direction that is diminished in amplitude but broader in time. The same effect occurs with the 1DF feedforward controller. However, the response of this controller is long enough with respect to the settling time of the feedback loop that the feedback loop is capable of diminishing the effect of the disturbance on the output.

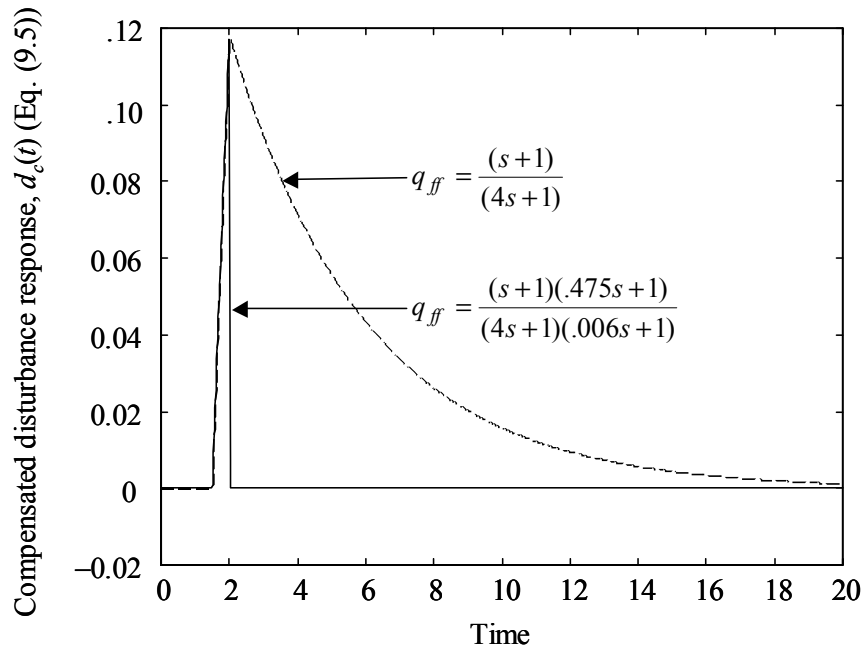

Figure 9.3 Comparison of compensated disturbance responses for Example 9.1.

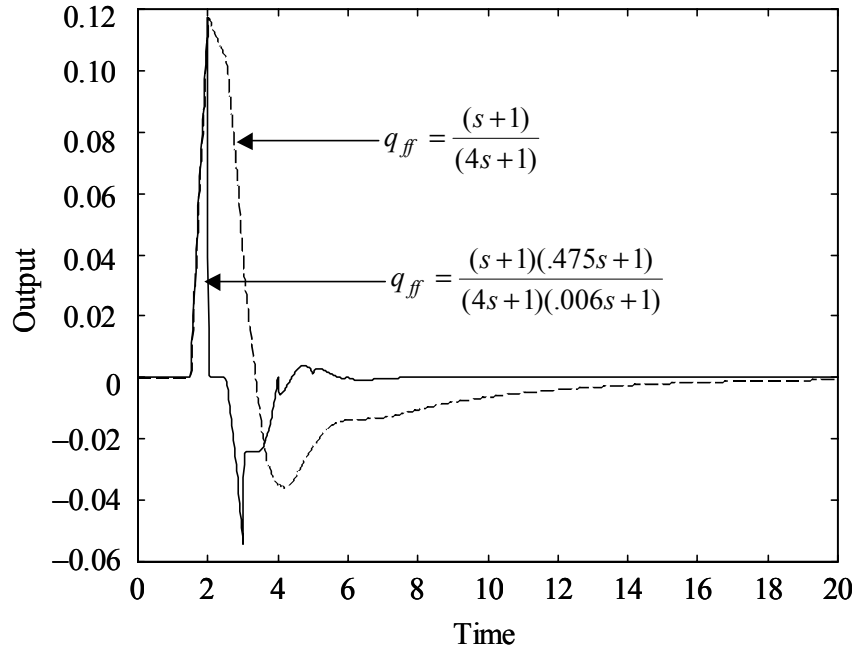

Figure 9.4 Comparison of feedforward plus feedback control system responses to a unit step disturbance for Example 9.1.

The PID controller used to obtain the responses shown in Figure 9.4 was obtained as described in Chapter 6. For a perfect model, an IMC filter time constant of 0.3 yields the following PID controller, which overshoots a step setpoint change by about 10%.

$$PID = 0.610(1 + 1/(1.24s) + .179s/(.090s + 1)). \quad (9.7c)$$

◆

It is possible to prevent the degradation in output response by making the feedback loop blind to the pulse generated by the feedforward controller. This is accomplished by subtracting the pulse from the feedback system, as shown in Figure 9.5.

Based on the responses given in Figures 9.3 and 9.4, the pulse-compensated diagram should be used only when the feedforward control system settling time, with the feedback loop open, is significantly faster than the feedback control system settling time. Thus, for Example 9.1 the pulse compensation of Figure 9.5 improves the response of the 2DF control system, which has a fast response, but degrades the response of the 1DF feedforward control system, which has a slow response relative to that of the feedback system.

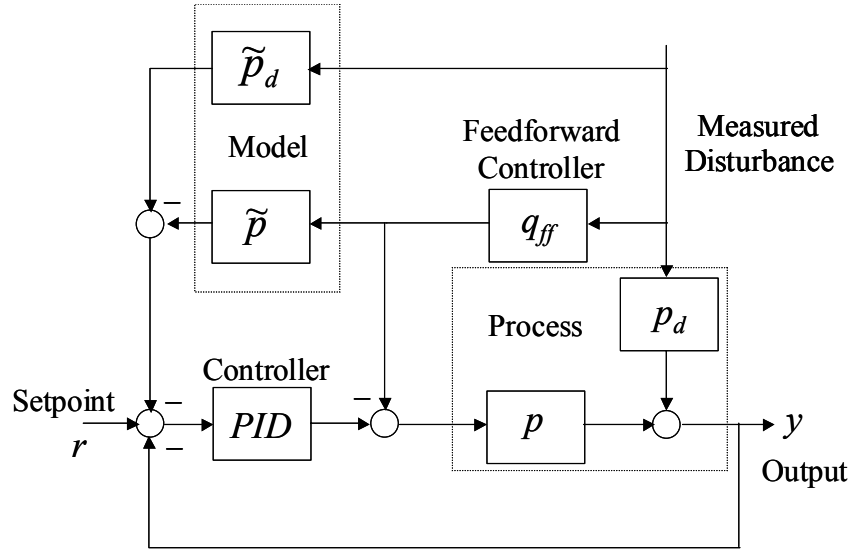

Figure 9.5 Pulse-compensated feedforward control system.

9.4 CONTROLLER DESIGN FOR UNCERTAIN PROCESSES

9.4.1 Gain Variations

Gain variations in either or both $p(s)$ and $p_d(s)$ can result in a nonzero value for the steady state effect of the compensated disturbance d_c (see Figure 9.1b), on the process output. The gain of the feedforward controller K_f should be chosen to minimize either the maximum magnitude of the steady-state compensated disturbance $d_c(\infty)$ or the ratio of the compensated to the uncompensated disturbance $d_c(\infty)/d_e(\infty)$. Mathematically, the problem can be expressed as

$$d_c(\infty)_{opt.} = \min_{K_f} \max_{K_p, K_d} |K_d - K_p K_f| \quad (9.8)$$

or

$$(d_c(\infty)/d_e(\infty))_{opt.} = \min_{K_f} \max_{K_p, K_d} |1 - K_p K_f / K_d|. \quad (9.9)$$

The maxima in equations (9.8) and (9.9) occur at the simultaneous upper bound of K_p and lower bound of K_d , and at the lower bound of K_p and the upper bound of K_d . The values of K_f that minimize these maxima are those values that equalize the values of the two extremes. That is, for Eq. (9.8)

$$(K_f)_{opt} = \left(\frac{\max(K_d) + \min(K_d)}{2} \right) \bigg/ \left(\frac{\max(K_p) + \min(K_p)}{2} \right), \quad (9.10)$$

$$\equiv (K_d)_{ave} / (K_p)_{ave}$$

and for Eq. (9.9)

$$(K_f)_{opt} = \left(\frac{\max(K_p / K_d) + \min(K_p / K_d)}{2} \right)^{-1}. \quad (9.11)$$

$$\equiv (K_p / K_d)_{ave}^{-1}$$

The feedforward controller gain given by Eq. (9.11) assures that the magnitude of the compensated disturbance effect $d_c(\infty)$ is always less than the magnitude of the uncompensated disturbance effect $d_e(\infty)$. That is, the action of the feedforward controller always improves the output response over that which would have been achieved without feedforward control. However, this feedforward controller gain also yields the same relative improvement if the ratio of (K_d / K_p) is at its maximum or its minimum, and this weighting tends to amplify the effect of large values of (K_d / K_p) on the output. On the other hand, the feedforward controller gain given by Eq. (9.10) can cause the compensated disturbance to be worse than the uncompensated disturbance in some situations. As we shall see from Example 9.2, the choice between equations (9.10) and (9.11) depends to a large degree on engineering judgment, and to some degree on the amount of uncertainty in the process and disturbance lag gains.

Example 9.2 Variation in Process and Disturbance Lag Gains

Case 1, Modest Uncertainty:

$$0.8 \leq K_p, K_d \leq 1.2; d = 1$$

From Eq. (9.10), we have $(K_f)_{opt} = 1$, and from Eq. (9.8), the worst-case compensated effect of the disturbance is

$$|d_c(\infty)|_{\max} = \max_{K_p, K_d} |K_d - K_p (K_f)_{opt}| d(\infty) = |K_d - K_p|_{K_p=8, K_d=1.2} = |K_d - K_p|_{K_p=1.2, K_d=.8} = 0.4.$$

The worst case uncompensated effect of the disturbance is $d_e(\infty)_{\max} = (K_d)_{\max} d(\infty) = 1.2$.

From Eq. (9.11) we have $(K_f)_{opt} = \left(\frac{3/2 + 2/3}{2} \right)^{-1} = 12/13$, and from Eq. (9.9.)

$$|d_c(\infty) / d_e(\infty)|_{\max} = \max_{K_p, K_d} \left| 1 - K_p K_f / K_d \right| = \left| 1 - \frac{(1.2)(12/13)}{.8} \right| = \left| 1 - \frac{(.8)(12/13)}{1.2} \right| = .385.$$

Since $d_e(\infty)_{\max} = (K_d)_{\max} d(\infty) = 1.2$, then

$$d_c(\infty)_{\max} = (.385)(d_e(\infty)_{\max}) = .46.$$

For most engineering situations the feedforward controller gain from Eq. (9.10) (i.e., $K_f = 1$) would be preferred because this minimizes the maximum effect of the compensated disturbance $|d_c(\infty)|_{\max}$ on the output (0.4 versus .46).

Case 2, Large Uncertainty:

$$1 \leq K_p, K_d \leq 3; d = 1$$

From Eq. (9.10) we have: $(K_f)_{opt} = 1$ and from Eq. (9.8), if $K_d = 1$, and $K_p = 3$, then the compensated effect of the disturbance is

$$d_c(\infty) = 1 - 3 = -2.$$

However, the uncompensated effect of the disturbance is only 1.0 since

$$d_e(\infty) = K_d d(\infty) = 1.0$$

From Eq. (9.11) we have $(K_f)_{opt} = \left(\frac{3+1/3}{2}\right)^{-1} = 3/5$, and from Eq. (9.9), if $K_d = 1$, and $K_p = 3$, then the compensated effect of the disturbance is

$$d_c(\infty) / d_e(\infty) = 1 - K_p (K_f)_{opt} / K_d = (1 - (3)(3/5)/1) = -0.8$$

Thus for the situation where $K_d = 1$, and $K_p = 3$, the feedforward gain given by Eq. (9.11) is clearly preferred. However, if the gains of K_d and K_p are reversed so that $K_d = 3$, and $K_p = 1$, then the uncompensated effect of the disturbance is 3.0, and the compensated effect of the disturbance for the feedforward gains given by Eq. (9.10) and Eq. (9.11) are 2 and 2.4 respectively. So, in the first instance the gain given by Eq. (9.11) is preferred, while in the second instance, the gain given by Eq. (9.10) is preferred. "You pays your money and takes your choice." The authors prefer the gain given by Eq. (9.11).

◆

9.4.2 Deadtime Variations

This section considers the effect of deadtime variations on the choice of feedforward controller deadtime. We assume that the process deadtime is on the order of, or greater than, the disturbance deadtime. Further, the relative order of the process $p(s)$ is the same as that of the disturbance transfer function $p_d(s)$, and all time constants are known exactly. The process description is therefore given by

$$y(s) = Kg(s)e^{-T_p s} u(s) + K_d g_d(s)e^{-T_d s} d(s), \quad (9.12)$$

where

$$g(0) = g_d(0) = 1, \quad \underline{T}_p \leq T_p \leq \bar{T}_p, \quad \underline{T}_d \leq T_d \leq \bar{T}_d, \quad \underline{K} \leq K \leq \bar{K}, \quad \underline{K}_d \leq K_d \leq \bar{K}_d$$

The feedforward controller is given by

$$q_f(s) = K_f g_d(s) e^{-\Delta s} / g(s), \quad (9.13)$$

where Δ is a parameter that we need to find.

Substituting Eq. (9.13) into Eq. (9.5) gives

$$d_c(s) = (K_d e^{-T_d s} - K K_f e^{-(T_p + \Delta)s}) g_d(s) d(s). \quad (9.14)$$

When $(T_d > T_p + \Delta)$, the maximum magnitude of the integral of $d_c(t)$ occurs when $(T_d - (T_p + \Delta))$ is a maximum. When $(T_d < (T_p + \Delta))$, the maximum magnitude of the integral of $d_c(t)$ occurs when $((T_p + \Delta) - T_d)$ is a maximum. Choosing Δ so that these two maxima are equal gives

$$\Delta = \frac{(\bar{T}_d + \underline{T}_d) - (\bar{T}_p + \underline{T}_p)}{2} \equiv (T_d)_{ave} - (T_p)_{ave}. \quad (9.15)$$

In Example 9.3 we present the results of simulations on two processes, each of which are similar to Example 9.1. In the first example, the deadtime between the measured disturbance and the output is on the order of the process deadtime, and hence perfect feedforward compensation is possible for most choices of models in the uncertain set. For this process we use a simple 1DF feedforward controller. In the second example, the deadtime between the measured disturbance and the output is smaller than the process deadtime, and hence perfect feedforward compensation is not possible. Therefore, for this process we use a 2DF feedforward controller.

Example 9.3 Disturbance and Process Deadtimes of Roughly the Same Size

$$p(s) = K e^{-T_p s} / (s+1); \quad 0.8 \leq K, T_p \leq 1.2 \quad (9.16a)$$

$$p_d(s) = K_d e^{-T_d s} / (4s+1); \quad 0.8 \leq K_d, T_d \leq 1.2 \quad (9.16b)$$

$$q_f(s) = K_f (4s+1) / (s+1) \quad (9.16c)$$

The feedforward controller given by Eq. (9.16c) has a deadtime of zero, since the difference between $(T_d)_{ave}$ and $(T_p)_{ave}$ is zero (see Eq. 9.15).

Figures 9.6a and 9.6b show the worst-case feedforward-only responses for the above process, using feedforward controller gains given by equations (9.10) and (9.11). Notice

that for a disturbance lag gain of 1.2 and a process gain of .8 (i.e., $K_d = 1.2$, $K = .8$), the controller gain given by Eq. (9.10) gives the better response. However, when the gains are reversed, (i.e., $K_d = .8$, $K = 1.2$), the controller gain given by Eq. (9.11) gives the better response.

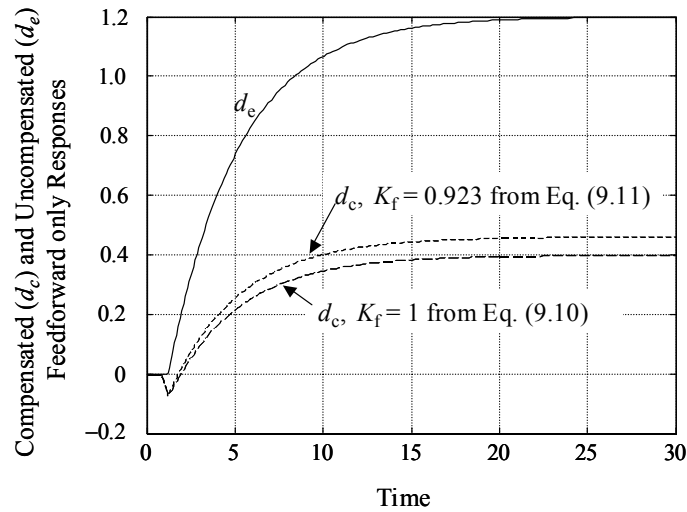

Figure 9.6a Example 9.3 responses of the feedforward-only control system to a unit step disturbance for $K_d = 1.2$, $K_p = .8$, $T_d = 1.2$, $T_p = .8$.

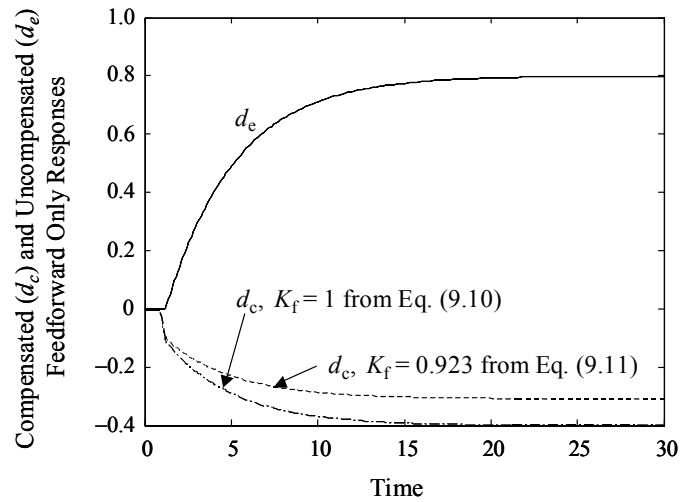

Figure 9.6b Example 9.3 responses of the feedforward-only control system to a unit step disturbance for $K_d = .8$, $K_p = 1.2$, $T_d = 1.2$, $T_p = .8$.

Figures 9.7a and 9.7b show worst-case feedforward plus feedback responses corresponding to the responses in figures 9.6a and 9.6b. The 1DF PID feedback controller was obtained using Mp tuning (see Chapter 7) and the IMC to PID controller approximation method of Chapter 6. The IMC filter time constant required to achieve an Mp of 1.05 is 1.04, and the resulting PID controller is

$$PID = 0.610(1 + 1/(1.24s) + .179s / (.090s + 1)). \quad (9.17)$$

The responses in figures 9.7a and 9.7b should be compared to those of a well-tuned 2DF feedback-only control system, as shown in Figure 9.8. The controller used to generate the responses in Figure 9.8 was obtained using the design and tuning methods described in Chapter 8. Clearly, the performance of the combined feedforward/feedback control system is superior to that of a standalone 2DF feedback control system.

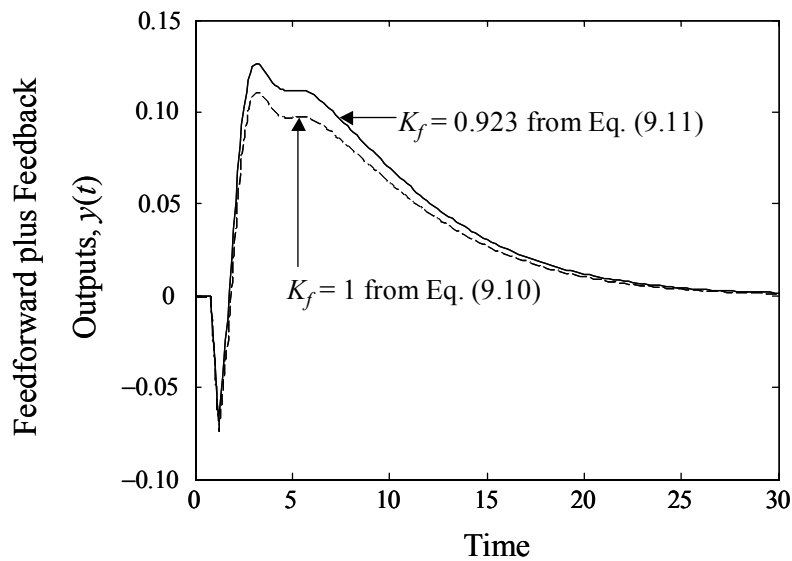

Figure 9.7a Example 9.3 output responses of the feedforward plus feedback control system to a unit step disturbance $K_d = 1.2$, $K = .8$, $T_d = 1.2$, $T_p = .8$.

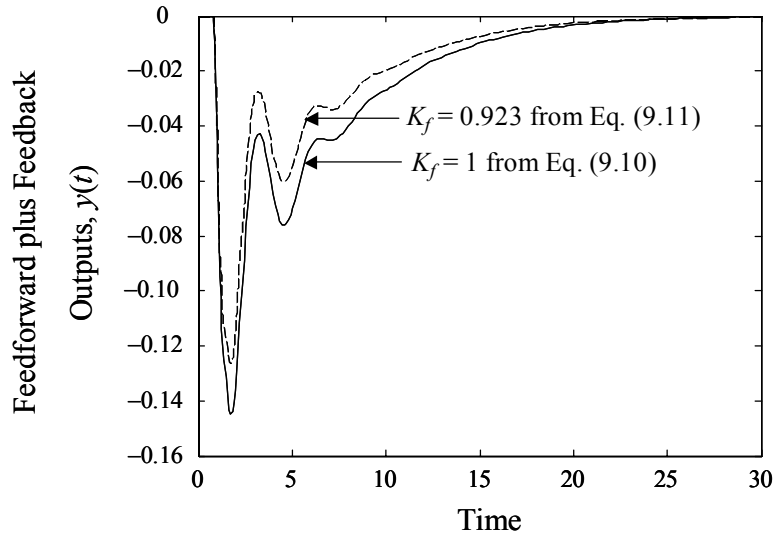

Figure 9.7b Example 9.3 output responses of the feedforward plus feedback control system to a unit step disturbance $K_d = .8$, $K_p = 1.2$, $T_d = 1.2$, $T_p = .8$.

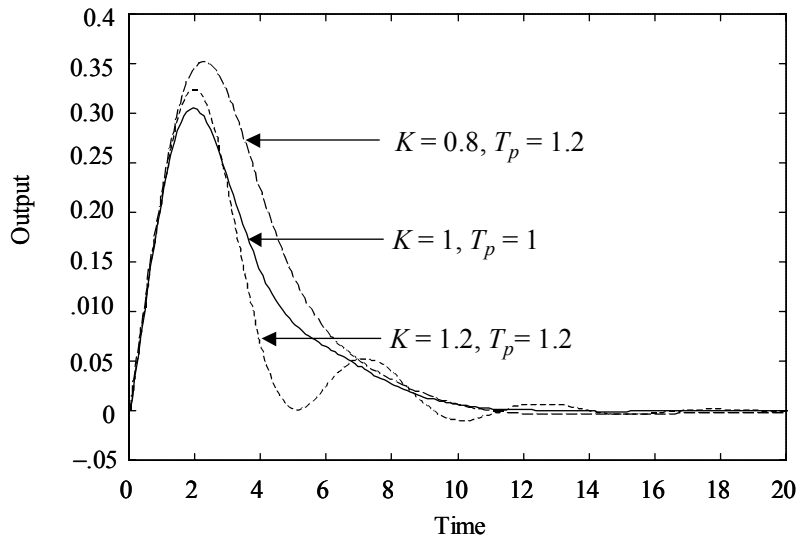

Figure 9.8 Example 9.3 responses of a 2DF feedback control system to a unit step disturbance with feedback controller = $3.52(1 + 1/(4.04s) + .965s)/(4.17s + 1)$.

The next example is the same as Example 9.3, except that the disturbance transfer function deadline is always smaller than the process deadline.

Example 9.4 Disturbance deadline < process deadline

$$p(s) = Ke^{-T_p s} / (s+1); \quad 0.8 \leq K, T_p \leq 1.2, \quad (9.18a)$$

$$p_d(s) = K_d e^{-T_d s} / (4s+1); \quad 0.8 \leq K_d \leq 1.2, \quad .4 \leq T_d \leq .6, \quad (9.18b)$$

$$\tilde{p}(s) = e^{-s} / (s+1); \quad \tilde{p}_d(s) = e^{-.5s} / (4s+1). \quad (9.18c)$$

The 1DF feedforward controller is the same as that of Eq. (9.7a):

$$q_{ff1}(s) = (s+1)/(4s+1). \quad (9.18d)$$

The 2DF feedforward controller is the same as that of Eq. (9.7b):

$$q_{ff2}(s) = (s+1)(.473s+1)/(4s+1)(0.006s+1). \quad (9.18e)$$

The PID feedback controller is the same as that of Eq. (9.17):

$$PID = 0.610(1+1/(1.24s) + .179s/(.090s+1)). \quad (9.18f)$$

As before, the following feedforward/feedback responses to a unit step disturbance should be compared with the 2DF feedback-only responses given by Figure 9.8. Figure 9.9 repeats the perfect model responses for the feedback controller of Eq. (9.18f). Notice that the undershoots in Figure 9.9 of the uncompensated controllers are less severe than those in Figure 9.4. This occurs because the feedback controller, Eq. (9.18f), is less aggressive than that of Eq. (9.7c) because Eq. (9.9f) has been tuned to accommodate the specified process uncertainty.

Figures 9.10 and 9.11 show typical worst-case responses of the 1DF and 2DF feedforward/feedback control systems. Unlike Figure 9.8, there is little difference in the responses of the compensated (via Figure 9.5) and uncompensated 2DF controllers, and both controllers perform better than the 1DF controller.

Figure 9.12 shows typical best-case responses that result when the difference between the disturbance deadline and process deadline is 0.2, which is the smallest in the set of uncertain parameters. The poorer behavior of the 2DF controllers relative to the 1DF controller arises from the fact that the 2DF feedforward controller, Eq. (9.18e), was obtained for a difference between the disturbance deadline and process deadline of 0.5.

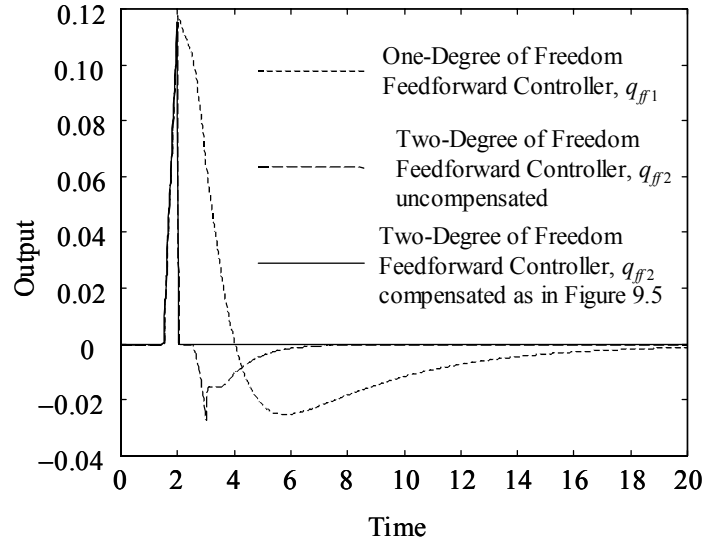

Figure 9.9 Responses of feedforward/feedback control systems to a unit step disturbance at time 1.0 for Example 9.4, $K = K_d = T_p = 1$, and $T_d = 0.5$.

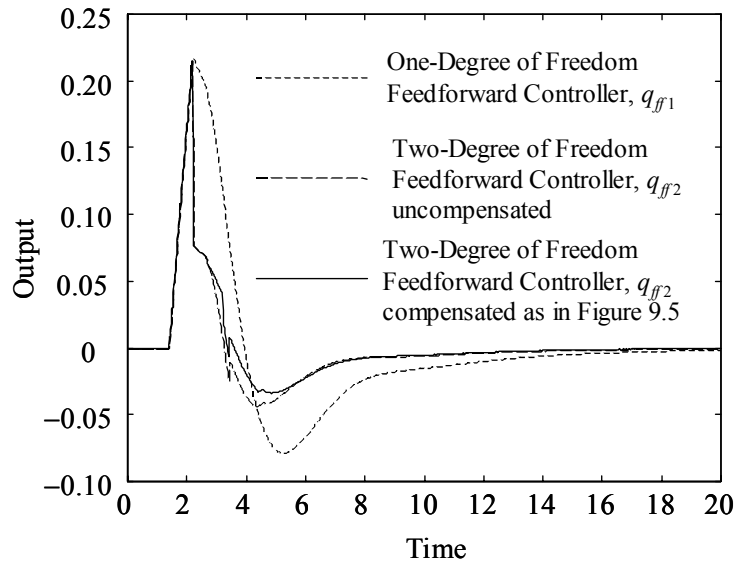

Figure 9.10 Responses of feedforward/feedback control systems to a unit step disturbance at time 1.0 for Example 9.4, and $K = K_d = T_p = 1.2$, and $T_d = 0.4$

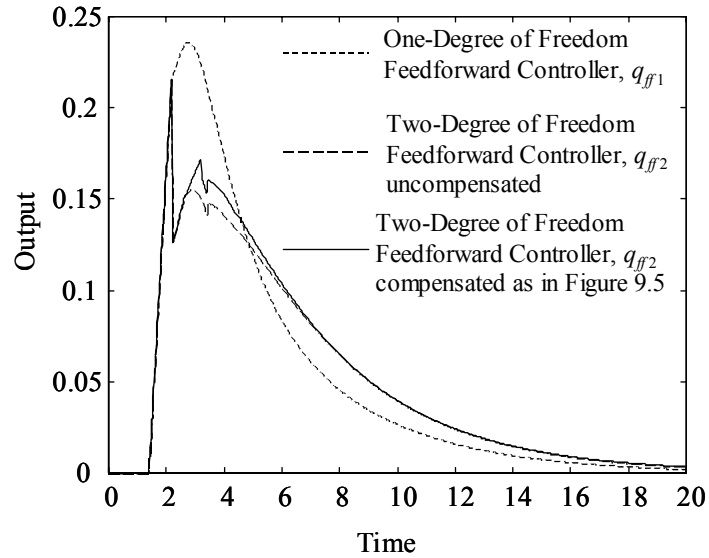

Figure 9.11 Responses of feedforward/feedback control systems to a unit step disturbance at time 1.0 for Example 9.4, $K = .8$, $K_d = T_p = 1.2$, and $T_d = 0.4$.

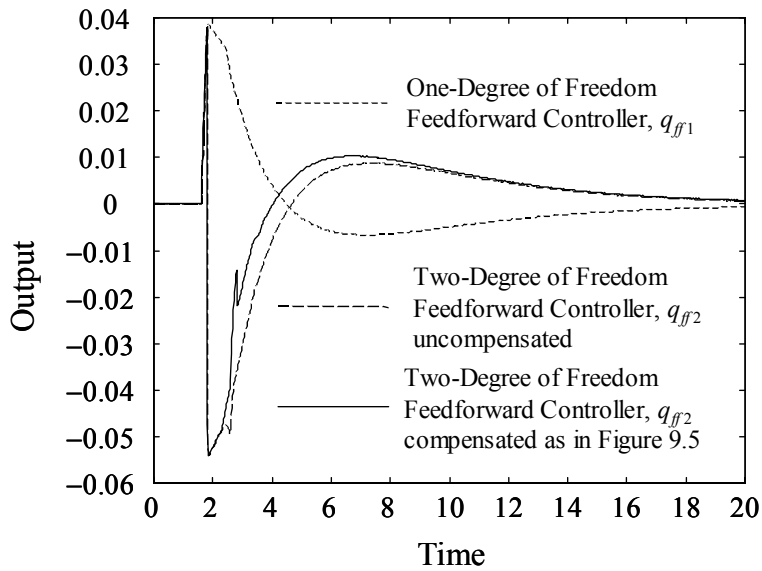

Figure 9.12 Responses of feedforward/feedback control systems to a unit step disturbance at time 1.0 for Example 9.4, $K = K_d = T_p = .8$, and $T_d = 0.6$.

Since the deviations from setpoint in Figure 9.12 are quite small relative to those in figures 9.10 and 9.11, our conclusion from these figures is that the 2DF feedforward controller design is preferred.



9.5 SUMMARY

A properly designed feedforward/feedback control system will always improve performance over a simple feedback control system, independent of the process uncertainty, provided only that the measured disturbance does not enter directly (i.e., with a unity transfer function) into the process output. However, as one might expect, the greater the process uncertainty, the less the potential improvement in response for processes at the extremes of the uncertainty ranges.

For an uncertain process, the feedforward controller gain should be chosen either as $K_f = (K_d)_{ave} / (K_p)_{ave}$ (see Eq. (9.10)) or as $K_f = (K_p / K_d)_{ave}^{-1}$ (see Eq. (9.11)), depending on the uncertainties in the gains and on control objectives. However, only the latter choice (i.e. Eq. (9.11)) guarantees that the feedforward/feedback controller will perform better than a simple feedback controller for all processes in the set of uncertain processes.

When the deadtime between the measured disturbance and the output is greater than the deadtime between the control and the output, then a feedforward controller should be designed like a single-degree-of-freedom IMC controller, except that the difference between the deadtimes is included in the controller.

When the deadtime between the measured disturbance and the output is less than the deadtime between the control and the output, then the feedforward controller should be designed as a 2DF IMC controller. If there is also relatively little process uncertainty, better performance can be achieved by modifying the feedforward control system structure to prevent the pulse generated by the feedforward action from being propagated around the feedback control loop.

Problems

Select and tune control systems for each of the following processes. The control objective is to control the measured output $y(t)$, and all disturbances $d_i(t)$ are measured.

$$9.1 \quad y(s) = \frac{2(1 - 2s)e^{-6s}}{(2s + 1)^2} u(s) + \frac{50e^{-4s}d(s)}{(50s + 1)}$$

$$9.2 \quad y(s) = \frac{e^{-10s}}{30s + 1} y_2(s) + d_1(s) \quad y_2(s) = \frac{e^{-5s}}{4s + 1} u(s) + d_2(s)$$

$$9.3 \quad y(s) = \frac{Ke^{-4s}}{s(\tau s + 1)}u(s) + \frac{K_d e^{-5s}}{s(\tau s + 1)}d(s) \quad 1 \leq K \leq 3; \quad 2 \leq \tau \leq 5; \quad 3 \leq K_d \leq 4$$

$$9.4 \quad y(s) = \frac{K_1 e^{-Ts}}{5s + 1}y_2(s) + d_1(s) \quad 1 \leq K_1 \leq 3, \quad 4 \leq T \leq 6$$

$$y_2(s) = \frac{K_2 e^{-s}}{3s + 1}u(s) + d_2(s) \quad 1 \leq K_2 \leq 5, \quad 0 \leq u(t) \leq 10$$

$$9.5 \quad y(s) = \frac{K_1 e^{-Ts}}{3s + 1}y_2(s) + d_1(s) \quad 1 \leq K_1 \leq 5; \quad 2 \leq T \leq 4$$

$$y_2(s) = \frac{K_2 e^{-s}}{2s + 1}u(s) + d_2 \quad 1 \leq K_2 \leq 5$$

$$9.6 \quad y(s) = \frac{K_1 e^{-Ts}}{3s + 1}y_1(s) + \frac{e^{-Ts}d_1(s)}{3s + 1} \quad 1 \leq K \leq 5 \quad 2 \leq T \leq 4$$

$$y_1(s) = \frac{K_2(-2s + 1)}{(2s + 1)^2}u(s) + \frac{d_2}{s + 1}$$

References

Seborg, D. E., T. F. Edgar, and D. A. Mellichamp. 1989. *Process Dynamics and Control*, John Wiley & Sons, NY.

